

RO

Deconectați aparatul de la sursa de alimentare înainte de a-l curăța.

Îndepărtați cu grijă praful. Folosiți o cârpă moale și curată, umedă, cu apă și săpun. Ștergeți cu o cârpă curată. Nu utilizați niciodată produse abrazive (pudră, vată de oțel) sau solvenți.

Pentru produse cu înveliș textil:

Materialul produsului are o tendință naturală de a se scărmoșa. Acesta nu este un defect dacă:

- Scărmoșarea poate fi îndepărtată ușor sau se reduce în timp.
- Cantitatea scamelor nu afectează semnificativ estetica produsului.

Material textil acoperit cu PU:

Materialul textil acoperit cu PU este prin natura sa sensibil la sebum și transpirație: curățarea frecventă a zonelor expuse trebuie efectuată folosind un produs non-acid, cum ar fi săpunul de Marsilia.

Pentru toate produsele:

Un produs își va schimba în mod natural forma și aspectul pe măsură ce căptușeala se lasă sau se deplasează în timp.

Pentru a prelungi forma produsului și a distribui uniform uzura, se recomandă insistent:

- Întoarceți pernele în mod regulat, dacă este posibil.
- Neteziți suprafața șezuturilor imediat după o utilizare prelungită și masați pernele pentru a le restabili umflarea.

Un produs relax clasic poate fi așezat lângă un perete. Cu toate acestea, este necesar să se asigure o distanță de cel puțin 0,3 m față de acesta pentru a putea utiliza corect produsul.

فصل الجهاز عن مصدر الطاقة قبل تنظيفه.
أزل الغبار بعناية. استخدم قطعة قماش ناعمة ونظيفة مبللة بالماء والصابون. جفف بقطعة قماش نظيفة.
لا تستخدم أبدًا أي مواد كاشطة (بودرة، صوف فولاذي) أو منيبات.

للمقاعد المغطاة بقماش:

- يميل نسيج مقعدك إلى التكتل بشكل طبيعي. لا يُعد هذا عيبًا إذا:
- سهولة إزالة التكتل أو بهتانته بمرور الوقت،
- عدم تأثير عدد التكتل بشكل كبير على جمالية المنتج.

النسيج المغطى بطبقة من البولي يوريثان:

النسيج المغطى بطبقة من البولي يوريثان حساس بطبيعته للدهون والعرق: يجب تنظيف المناطق المكشوفة بشكل متكرر باستخدام منتج غير حمضي مثل صابون مارسيليا.

لجميع المقاعد:

- يتغير شكل المقعد ومظهره بشكل طبيعي مع ترحل الحشوة أو تغييرها بمرور الوقت. لإطالة عمر منتجك وتوزيع التآكل بالتساوي، يُنصح بشدة بما يلي:
- قلب الوسائد بانتظام، إن أمكن.
- تنعيم سطح المقاعد فورًا بعد الاستخدام المطول وتديل الوسائد لاستعادة انتفاخها.
- يمكن وضع مقعد الاسترخاء الكلاسيكي على الحائط. مع ذلك، من الضروري ترك مسافة لا تقل عن 0.3 متر بينه وبين الكرسي لفرده بشكل صحيح.

Ce produs fait l'objet d'une consigne de tri.



<https://quefairedemesdechets.fr>



B005039

(FR) NOTICE DE MONTAGE (EN) ASSEMBLY INSTRUCTIONS

(RO) INSTRUȚIUNI DE MONTAJ نصائح التنظيف

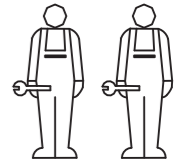

A140x190

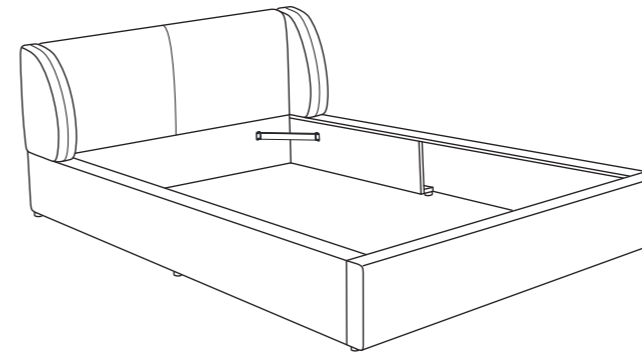

B160x200
C180x200

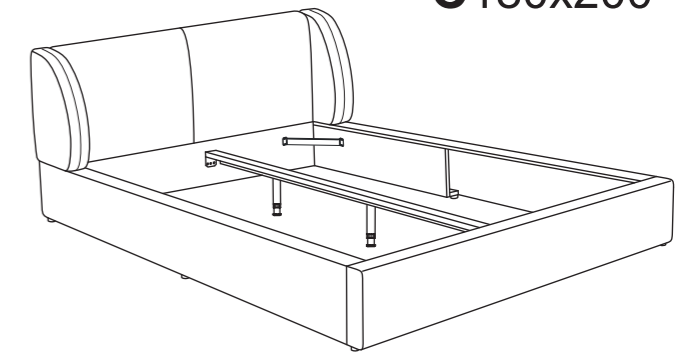

La nature vous remercie !

En achetant votre produit en kit, vous contribuez à préserver l'environnement.

Nature thanks you !

By buying your product knock-down packed, you're helping to protect the environment.

Réduction des émissions de carbone

Nos produits en kit **compacts** nécessitent moins d'espace lors du **transport** ce qui **réduit** les émissions de carbone.

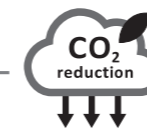

Carbon emission reduction

Our **compact** knock-down products require less space during **transportation**, thus **reducing** carbon emissions.

Facilité de réparation et de remplacement

Au besoin, vous pouvez uniquement remplacer la partie endommagée, **prolongeant** ainsi la **durée de vie** du produit.



Ease of repair and replacement

When needed, you can simply replace the damaged part, thereby **extending the lifespan** of the product.

Longévité et Adaptabilité

La conception en kit permet la **réversibilité** afin de **s'adapter** à vos différents **besoins** dans le temps.

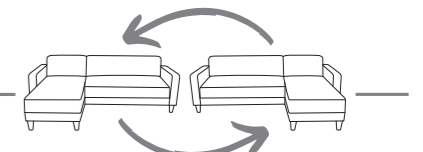

Longevity and adaptability

The modular design allows for **reversibility**, **adapting** to your various **needs** over time.

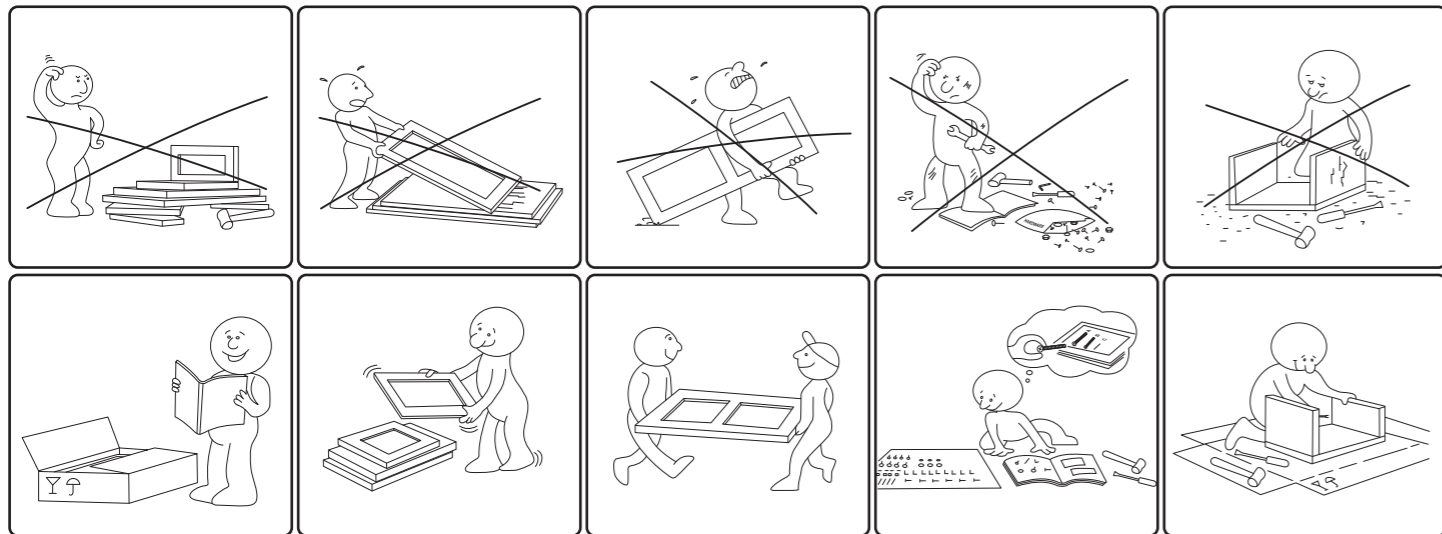

FR IMPORTANT — Veuillez lire attentivement — Conservez ce document pour référence ultérieure.

- À monter soi-même.
- Ne convient pas aux enfants de moins de 6 (six) ans.
- Ne pas assembler ni utiliser le meuble si des pièces sont cassées, endommagées ou manquantes. Utiliser uniquement des pièces de rechange approuvées par le fabricant.
- Vérifier la présence et l'état de toutes les fixations et pièces avant de commencer l'assemblage.
- Utiliser uniquement les outils fournis ou recommandés.
- Serrer correctement les fixations avec les outils fournis ou recommandés.
- Un assemblage, un serrage ou une manipulation incorrects peuvent fragiliser les assemblages et/ou les pièces.
- Tenir les jeunes enfants éloignés pendant l'assemblage. Présence de petites pièces susceptibles d'être avalées.
- Utilisez votre produit sur une surface plane et stable.
- Ne déplacez pas les meubles chargés.
- Tous les éléments de fixation doivent être correctement serrés et vérifiés régulièrement, puis resserrés si nécessaire.

AVERTISSEMENT : Ce siège n'est pas destiné aux personnes souffrant d'un handicap physique et nécessitant une position assise prolongée et fréquente.

AVERTISSEMENT : Ce produit est destiné à un usage récréatif ou de détente. Ce produit n'est pas conforme aux normes en vigueur relatives aux dispositifs médicaux.

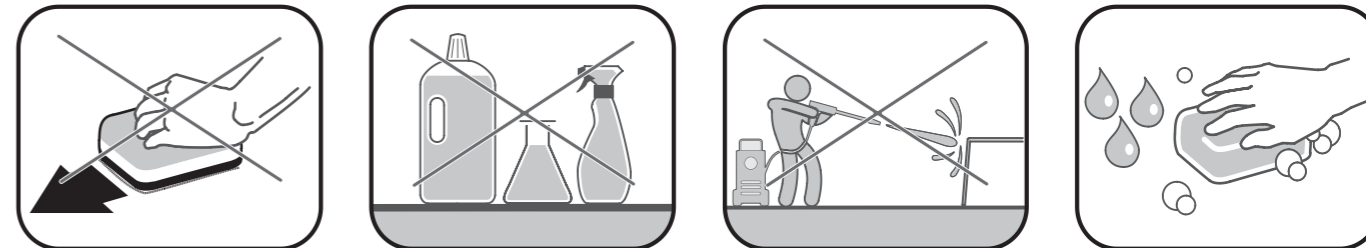

FR

Débrancher l'appareil de la source d'alimentation avant de le nettoyer.

Enlevez soigneusement la poussière. Utilisez un chiffon doux, propre et humide avec de l'eau savonneuse. Essayez avec un chiffon propre.

N'utilisez jamais de produit abrasif (poudre, laine d'acier) ni de solvants.

Les revêtements textiles des produits:

Le tissu de votre produit aura une tendance naturelle à boulocher. Ceci n'est pas un défaut dès lors que:

- Les bouloches peuvent facilement être enlevées ou s'estompent avec le temps.
- Le nombre de bouloches n'affecte pas sensiblement l'esthétique de votre produit.

Les revêtements PU:

Le revêtement PU est sensible par nature au sébum et à la sueur: un nettoyage fréquent en fonction de l'utilisation des zones exposées est à effectuer à l'aide d'un produit non acide de type savon de Marseille.

Pour tous les produits:

Un produit changera tout naturellement de forme et d'aspect sous l'effet de l'affaissement ou du déplacement du rembourrage dans le temps.

Afin de prolonger le gonflant de votre produit et de répartir l'usure de façon régulière, Il est fortement conseillé:

- De retourner régulièrement les coussins si cela est possible.
- De relisser la surface des assises immédiatement après une utilisation prolongée et de masser les coussins pour leur redonner du gonflant.

Un produit relax classique peut se mettre contre un mur. Néanmoins, il est nécessaire de prévoir à minima 0,3 m de distance avec ce dernier afin de pouvoir déployer votre siège correctement.

EN

Disconnect the appliance from the power source before cleaning it.

Carfully remove the dust. Use a soft and clean damp cloth with soapy water. Wipe dry with a clean cloth.

Never use an abrasive product (powder, steel wool) or solvents.

For products with textile covering:

Your product fabric will have a natural tendency to pill. This is not a defect if:

- Pilling can easily be removed or fade over time.
- The number of pills does not significantly affect the aesthetics of your product.

PU coated textile:

The PU coated textile is by nature sensitive to sebum and sweat: frequent cleaning of the exposed areas is to be carried out using a non-acid product such as Marseille soap.

For all products:

A product will naturally change shape and appearance as the padding sags or shifts over time. In order to prolong the shape of your product and evenly distribute wear, it is strongly recommended:

- Turn the cushions over regularly, if possible.
- To smooth the surface of the seats immediately after prolonged use and to massage the cushions to restore their swelling.

Classic relax seat can be placed against a wall. Nevertheless, it is necessary to provide at least 0.3 m distance with it in order to be able to deploy your seat correctly.

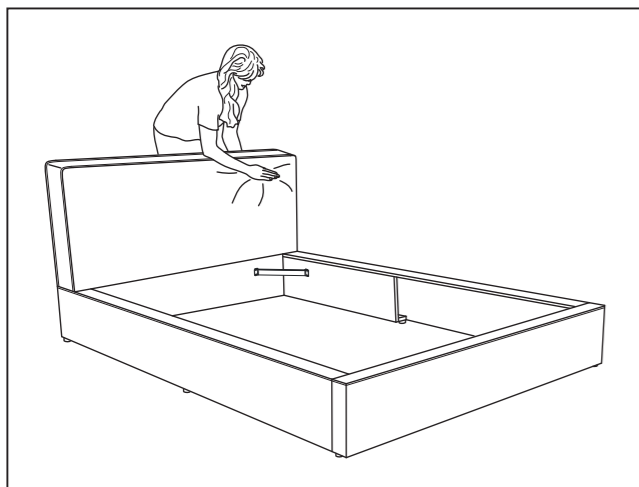
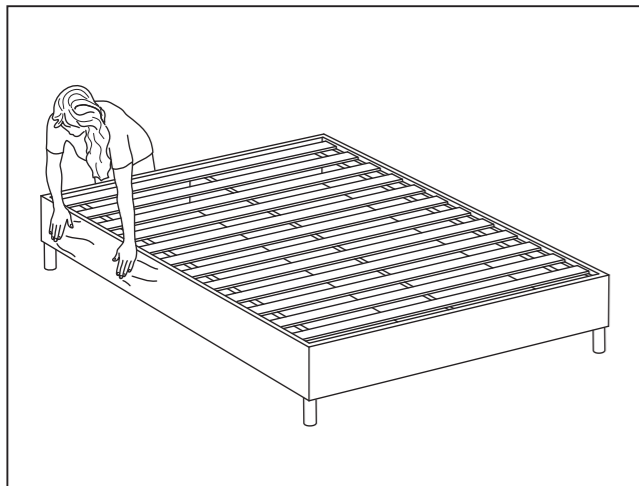
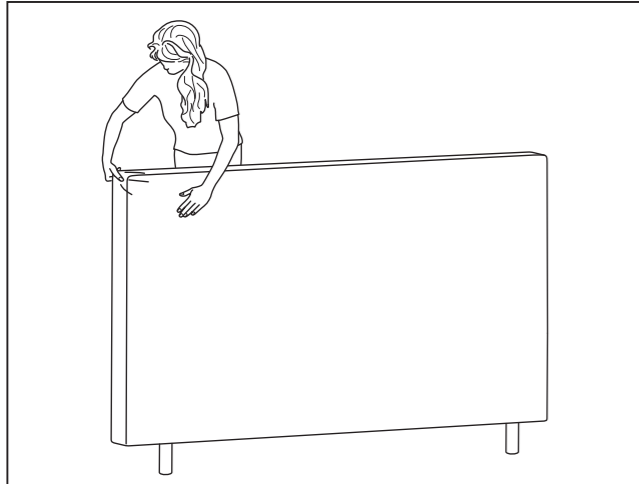
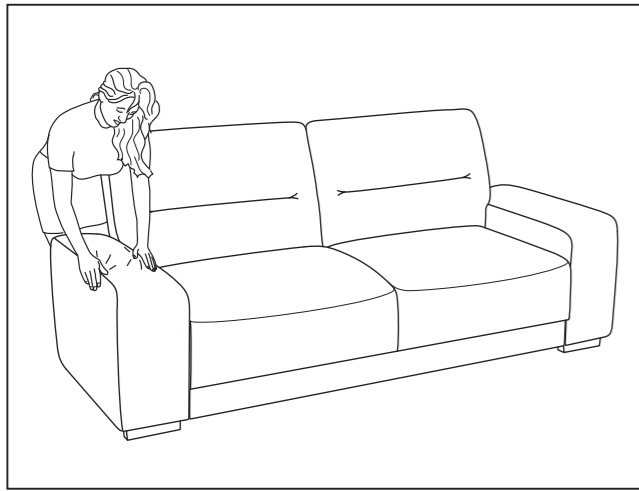

FR Cher client,

En raison du transport et de son emballage optimisé, votre nouveau produit peut présenter quelques plis disgracieux.

Afin d'y remédier, n'hésitez pas à lisser, tapoter et «masser» la housse, comme indiqué dans les illustrations.

Cela redonnera au produit son aspect originel et attrayant.

Nous souhaitons que votre nouveau produit vous offre entière satisfaction.

Votre équipe de création

EN Dear customers,

As a result of transport and use, your new product is somewhat "stressed" and this is noticed on her. Because of this:

*Smooth, knock and shake all the upholstery as appropriate, as shown in the illustrations.

*This leaves the product looking beautiful, prim and attractive.

We want your new product to offer you full satisfaction.

Your creative department team

RO Stimați clienți,

În urma transportului solicitant și a utilizării de zi cu zi, produsul dvs. este puțin "stresat" și acest lucru se observă.

De aceea:

Neteziți, bătați și scuturați puțin toate tapițeriile în mod corespunzător, după cum se indică în ilustrații.

Acest lucru conferă produsului frumusețe, eleganță și atractivitate.

Vă dorim ca produsul dvs. să vă ofere satisfacții depline.

Departamentul dvs. de creație produse

عزيزي الزبون:

نظرًا للنقل وتعبئته المحسنة، قد يُظهر كنبتك الجديدة بعض التجاعيد غير الجميلة. للقضاء عليها، لا تتردد في ترك الغطاء يتدلى وتدليكه، كما هو موضح في الصور.

سيعيد ذلك إلى الكنبية مظهرها الأصلي الجذاب.

نتمنى لك أن تكون راضيا على كنبتك الجديدة.

فريق التصميم

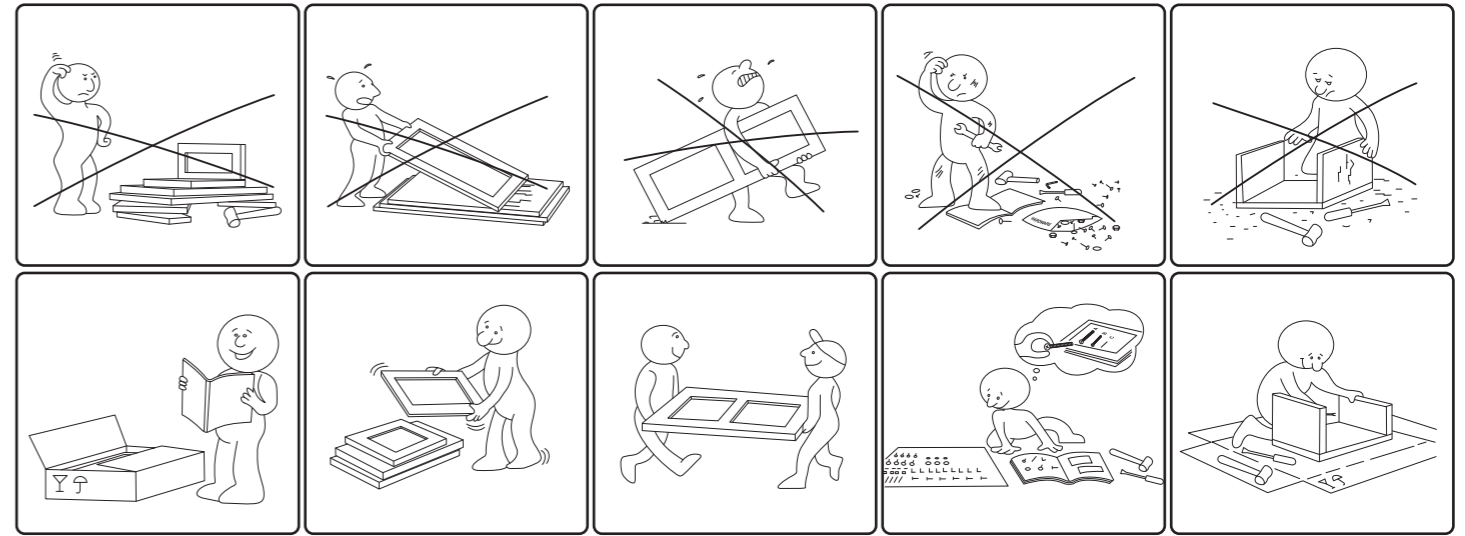

EN IMPORTANT — Please read carefully — Keep for future reference.

- To assemble by yourself.
- Not suitable for children under 6 (six) years old.
- Do not assemble or use the furniture if any parts are broken, damaged, or missing, and only use spare parts approved by the manufacturer.
- Check the presence and state of all hardware and parts before beginning assembly.
- Use only the tools provided or recommended.
- Tighten fasteners properly with the tools provided or recommended.
- Improper assembly, wedging, or handling can weaken the assemblies and/or parts.
- Keep young children away during assembly. Presence of Small parts liable to be swallowed.
- Use your product on stabilized, level ground.
- Do not move loaded furniture.
- All joining devices should be properly tightened and regularly checked, and re-tightened, if necessary.

WARNING: Do not use this seat for people suffering of a physical handicap and needing a seated continue and frequent position.

WARNING: This product shall be used in a frame of leisure or relaxation. This product does not comply with the norms in force for medical material.

OPTION SOMMIER RELEVABLE

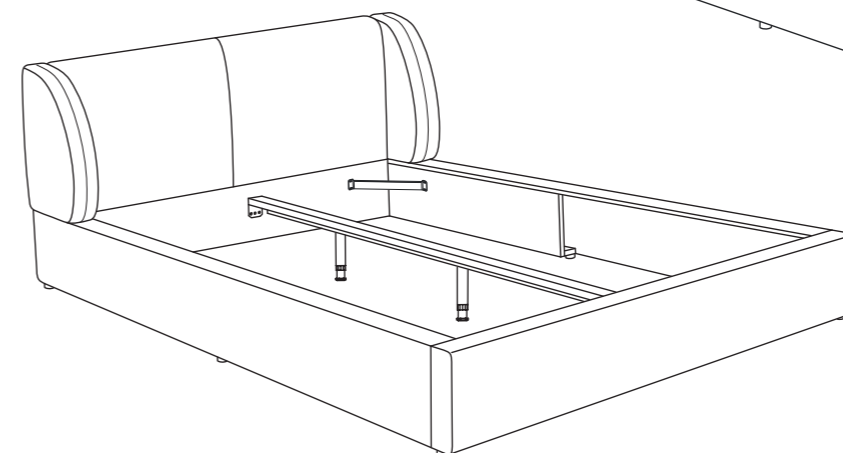
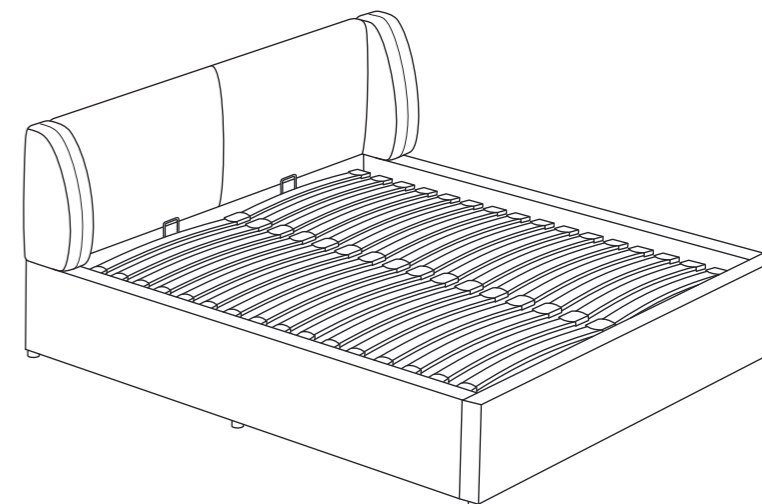
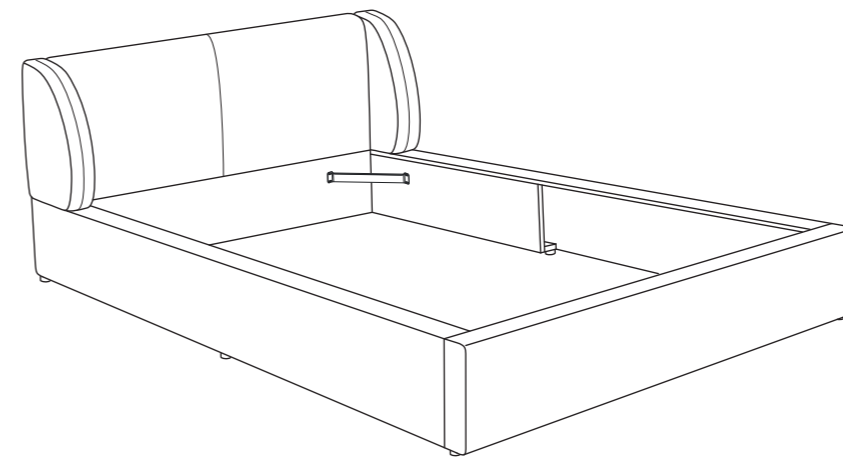
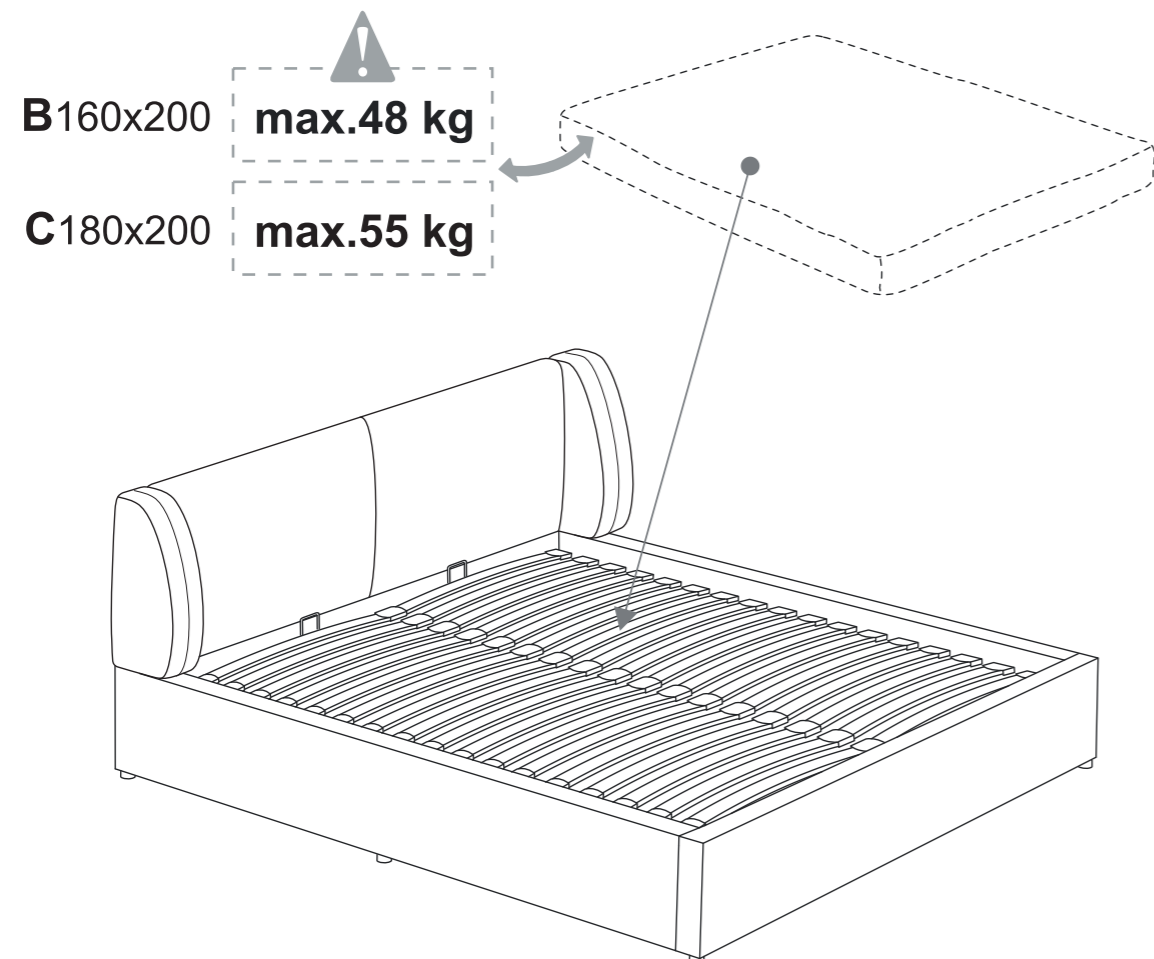
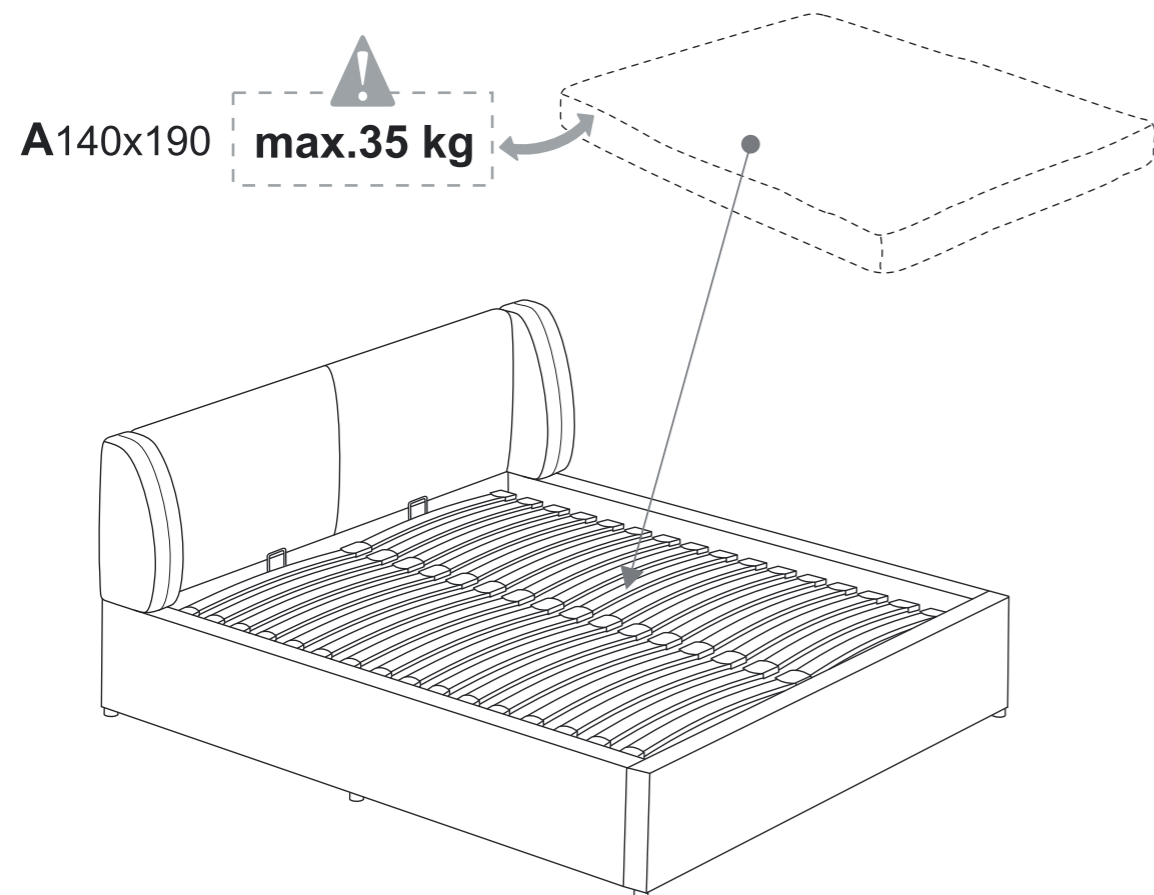

 ^(FR) À usage domestique / ^(EN) For domestic use / ^(RO) Pentru uz casnic / للاستعمال المنزلي فقط

^(FR) Les meubles contenant des panneaux à base de bois peuvent émettre des substances polluantes dans l'air intérieur. Il est donc recommandé, après l'installation du meuble, d'aérer fréquemment la pièce pendant au moins quatre semaines.

^(EN) Furniture containing wood-based panels can emit pollutants into the indoor air. It is therefore recommended, after the installation of the furniture, to ventilate the room frequently for at least four weeks.

^(RO) Mobilierul care conține panouri pe bază de lemn poate emite substanțe poluante în aerul din interior. Prin urmare, după instalarea mobilei, este recomandată aerisirea frecventă a camerei timp de cel puțin patru săptămâni.

قد تصدر الأثاث التي تحتوي على ألواح خشبية مواد ملوثة للهواء الداخلي. لذلك، يُنصح بتهوية الغرفة بانتظام بعد تركيب الأثاث لمدة لا تقل عن أربعة أسابيع



FIXATION SOMMIER

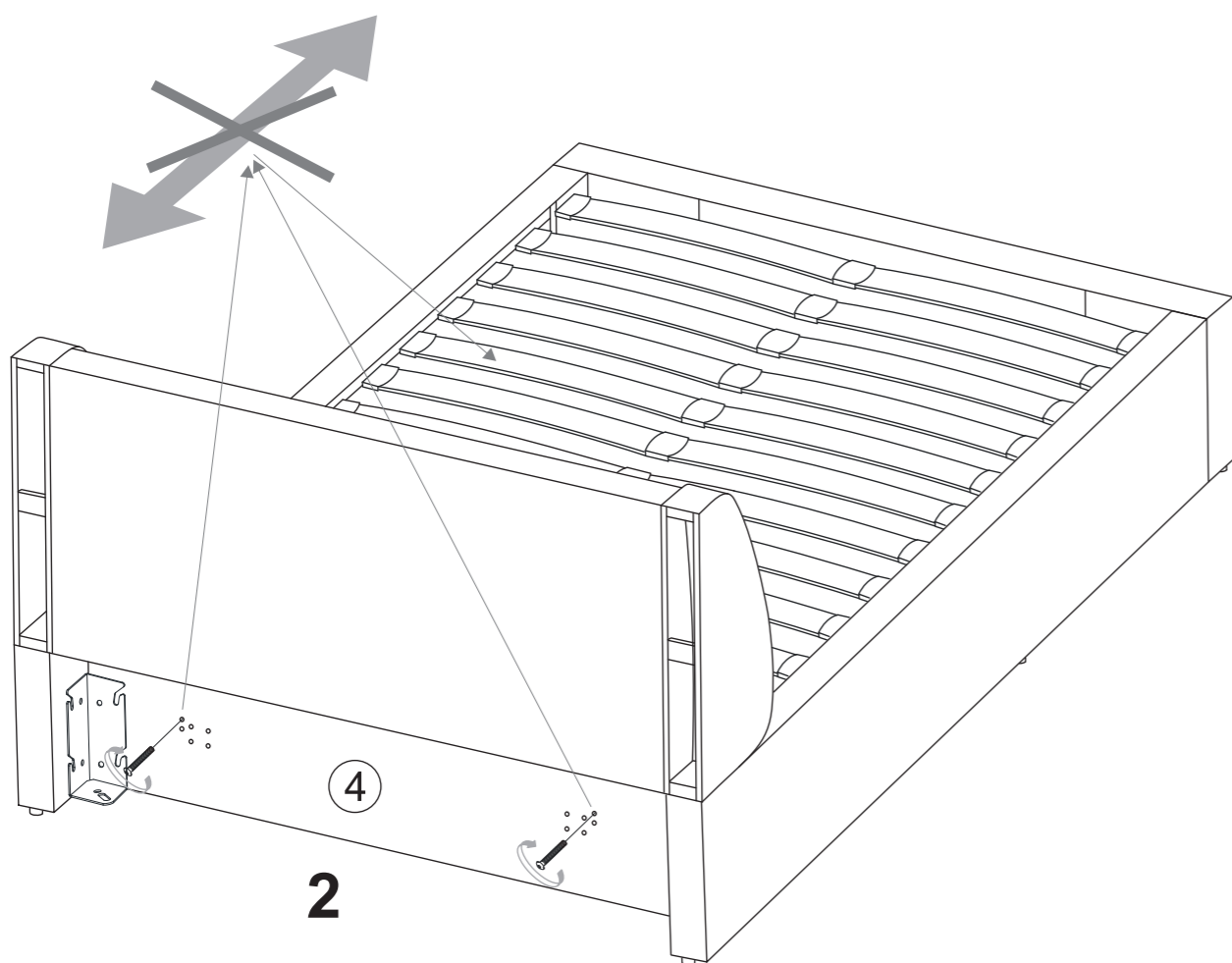
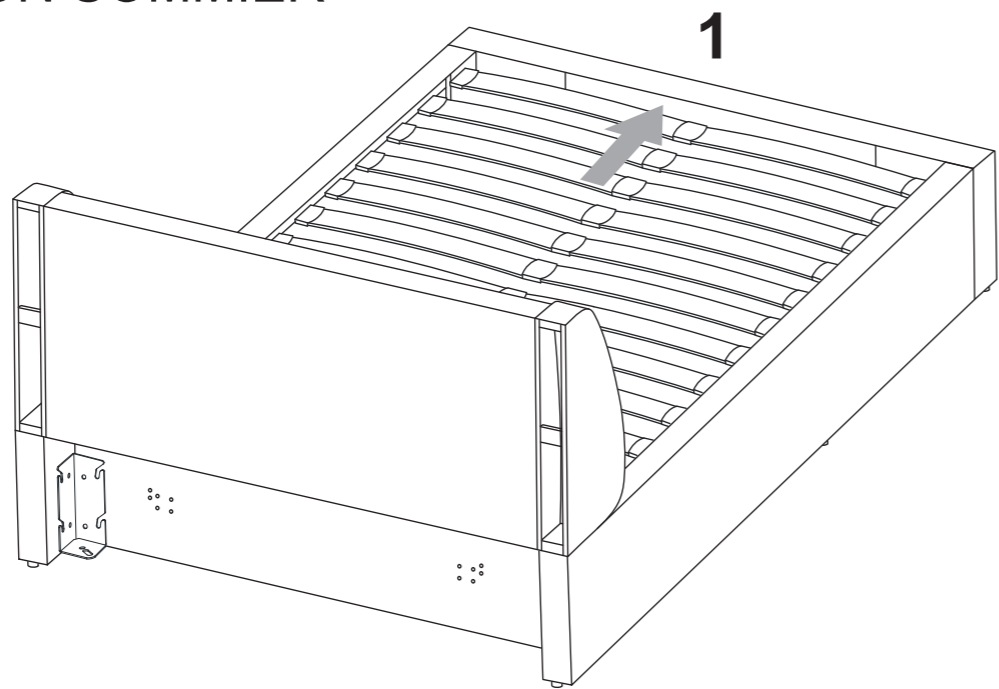

Bx2

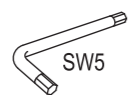

R

SN (FR) Le numéro de série des colis (EN) The serial number of the parcels

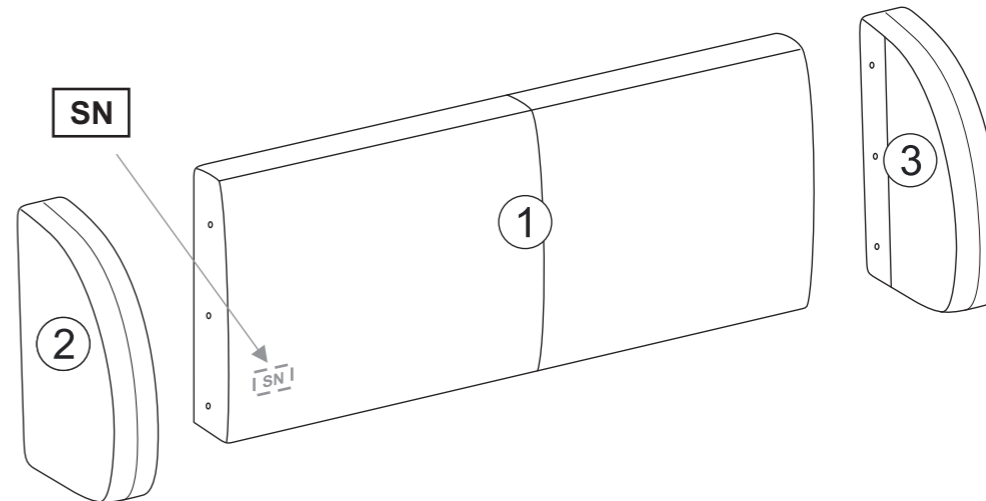

A140x190

C1/2

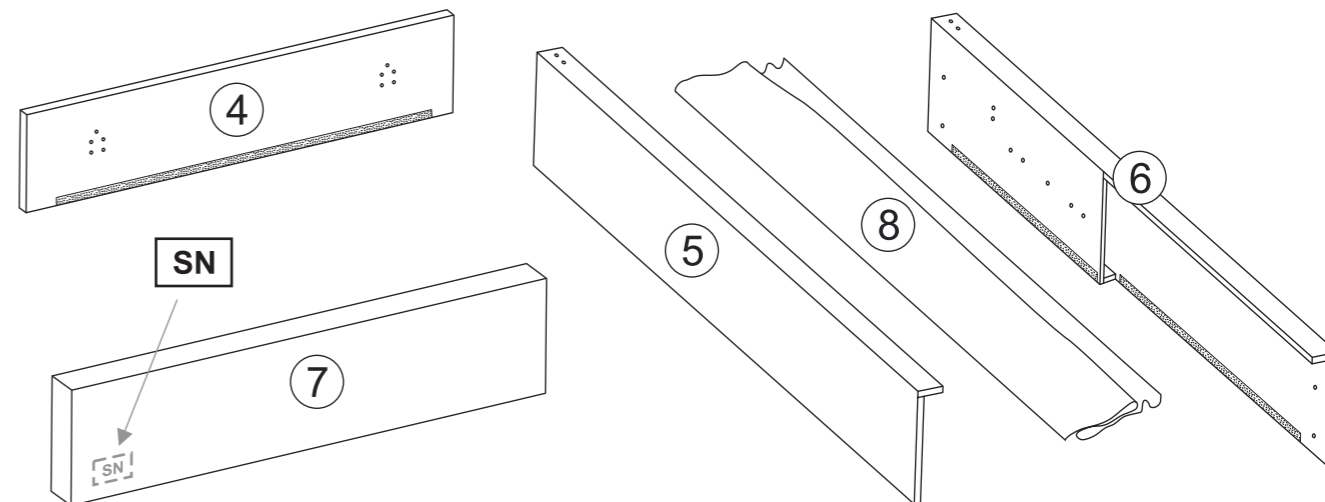

B160x200 / C180x200



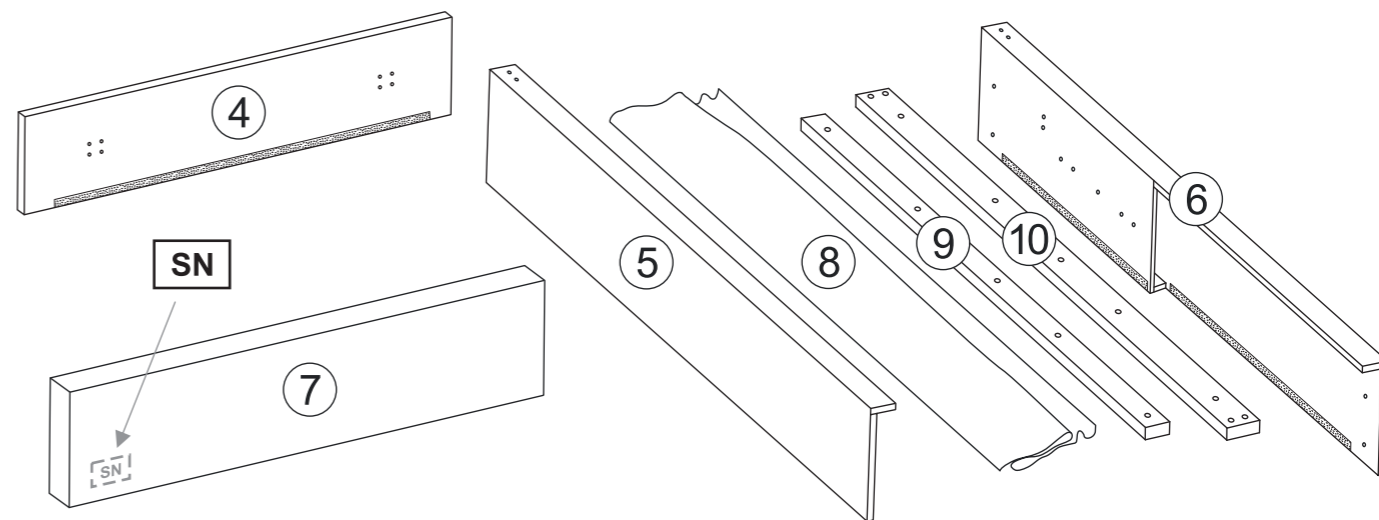



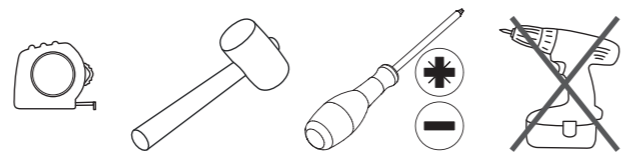

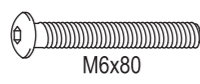

C2/2

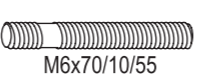
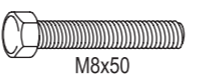
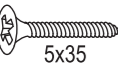
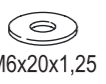
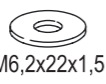

C2'/2

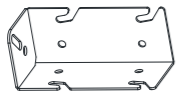

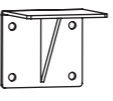
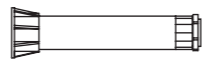
A140x190

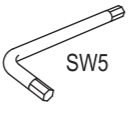
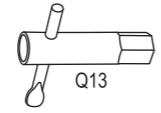
 M6x20 Ax42	 M6x80 Bx2	 M6x80 Cx4	 M6x70/10/55 Dx6	 M8x50 Ex1
 5x35 Fx6	 M6x20x1,25 Gx14	 M6,2x22x1,5 Hx4	 M8x24x2 Ix1	 M6 Jx6
 M8 Kx1	 Lx4	 Mx4	 Nx2	 Ox1
 Px6	 Qx6	 SW5 Rx1	 Q13 Sx1	

38





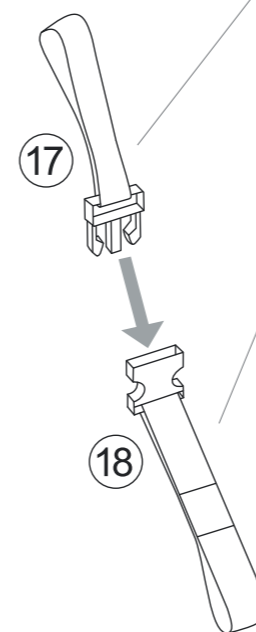
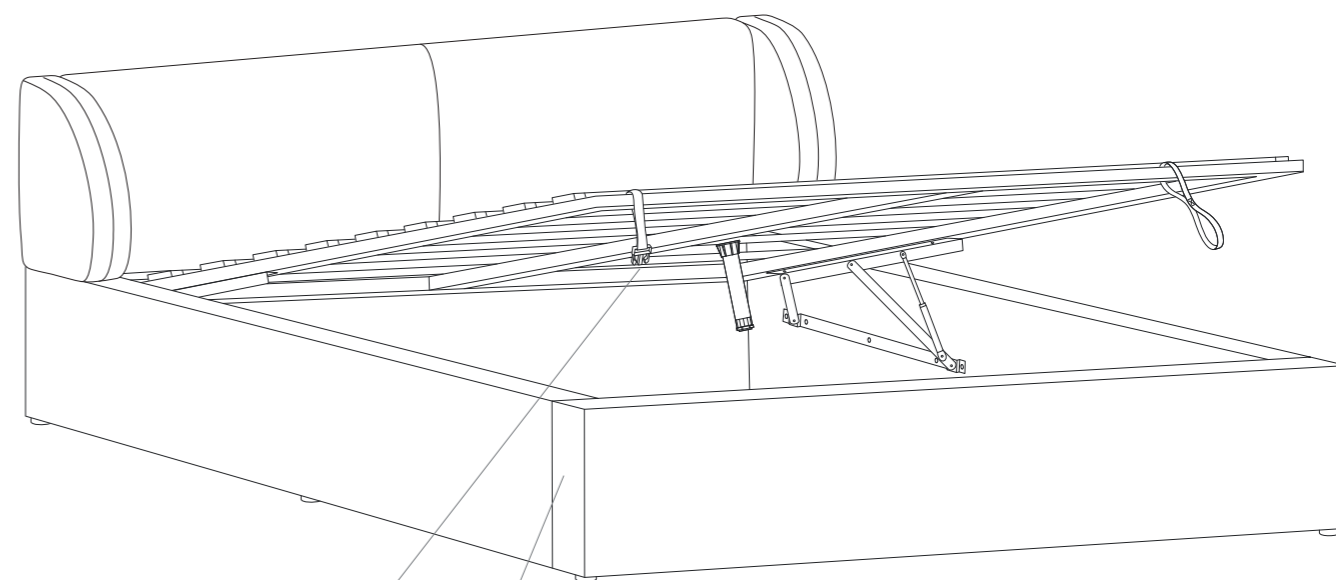



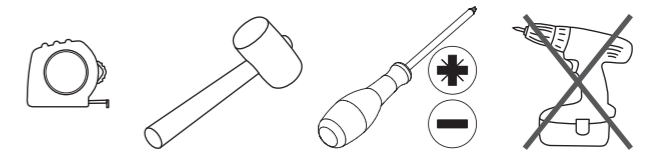
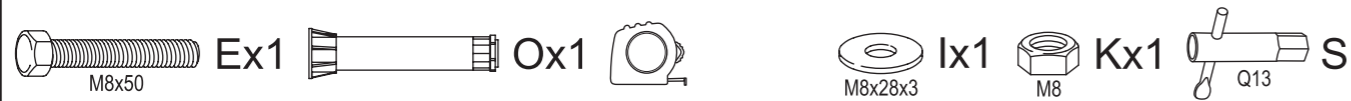
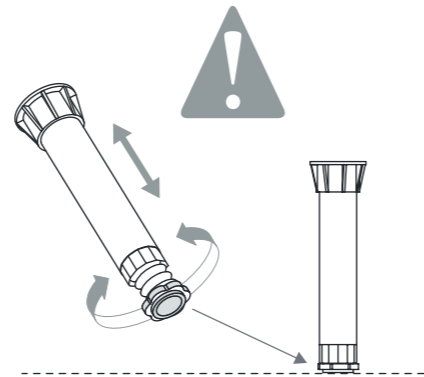
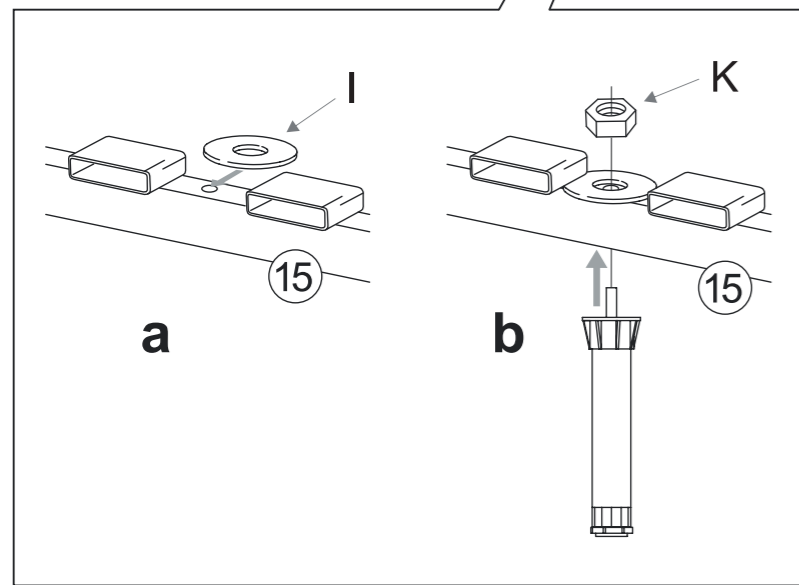
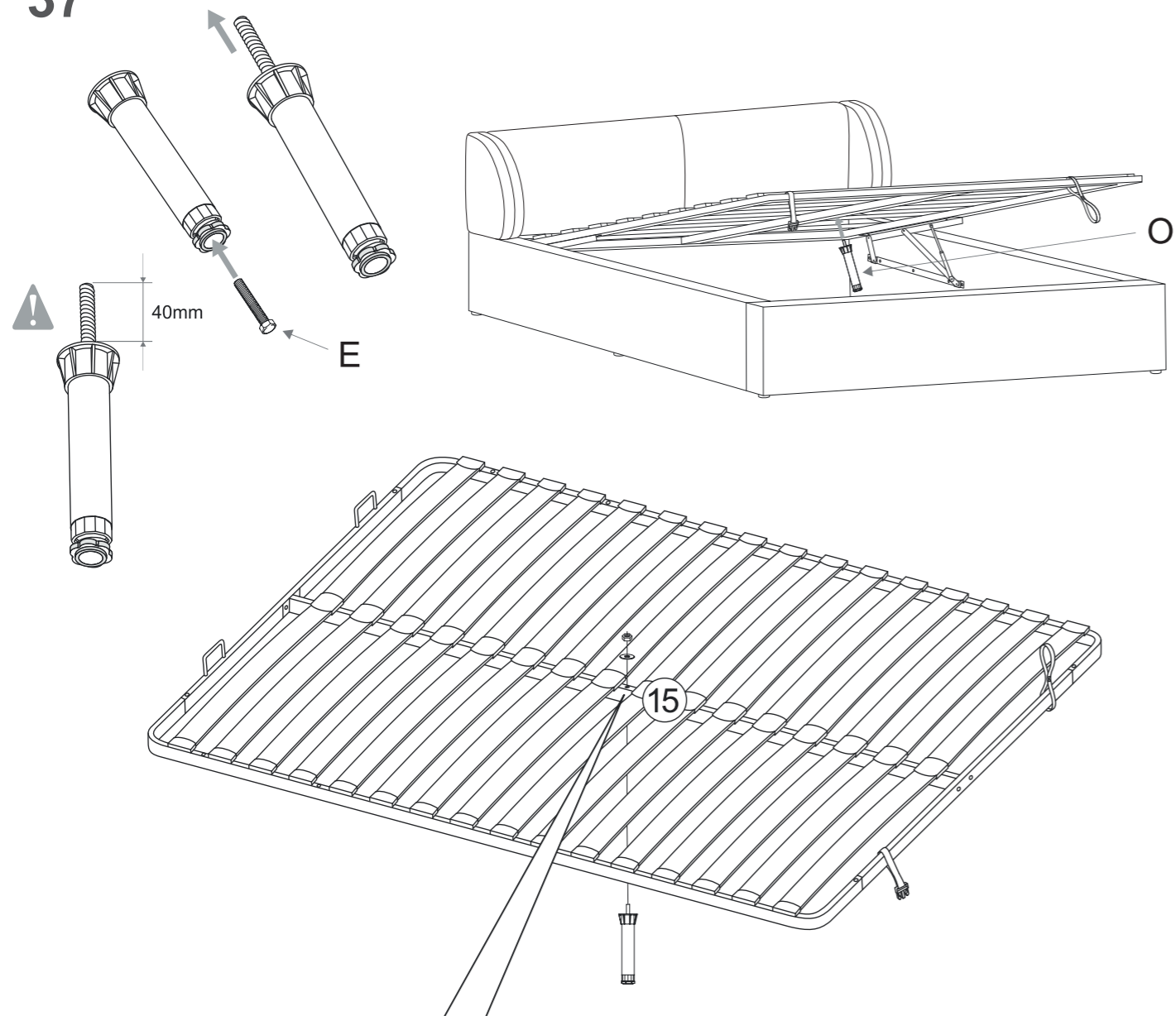



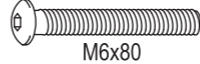
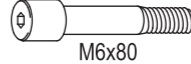

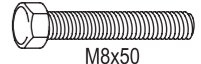



Risque de pincement lors de la fermeture du coffre
 Risk of pinching when closing the trunk
 Risc de ciupire la închiderea lăzii
 خطر التعرض للقرص عند إغلاق الصندوق

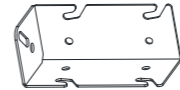

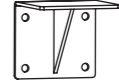
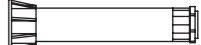
37

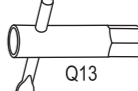

B160x200 / C180x200

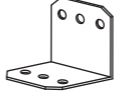
 M6x20 Ax42	 M6x80 Bx2	 M6x80 Cx4	 M6x70/10/55 Dx6	 M8x50 Ex2
 5x35 Fx6	 M6x20x1,25 Gx14	 M6,2x22x1,5 Hx4	 M8x24x2 Ix5	 M6 Jx6
 M8 Kx2	 Lx4	 Mx4	 Nx2	 Ox2
 Px6	 Qx6	 SW5 Rx1	 Q13 Sx1	 M8x45 Tx3
 Ux2				



1

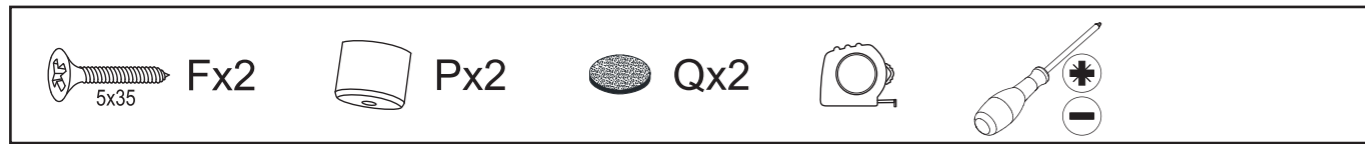
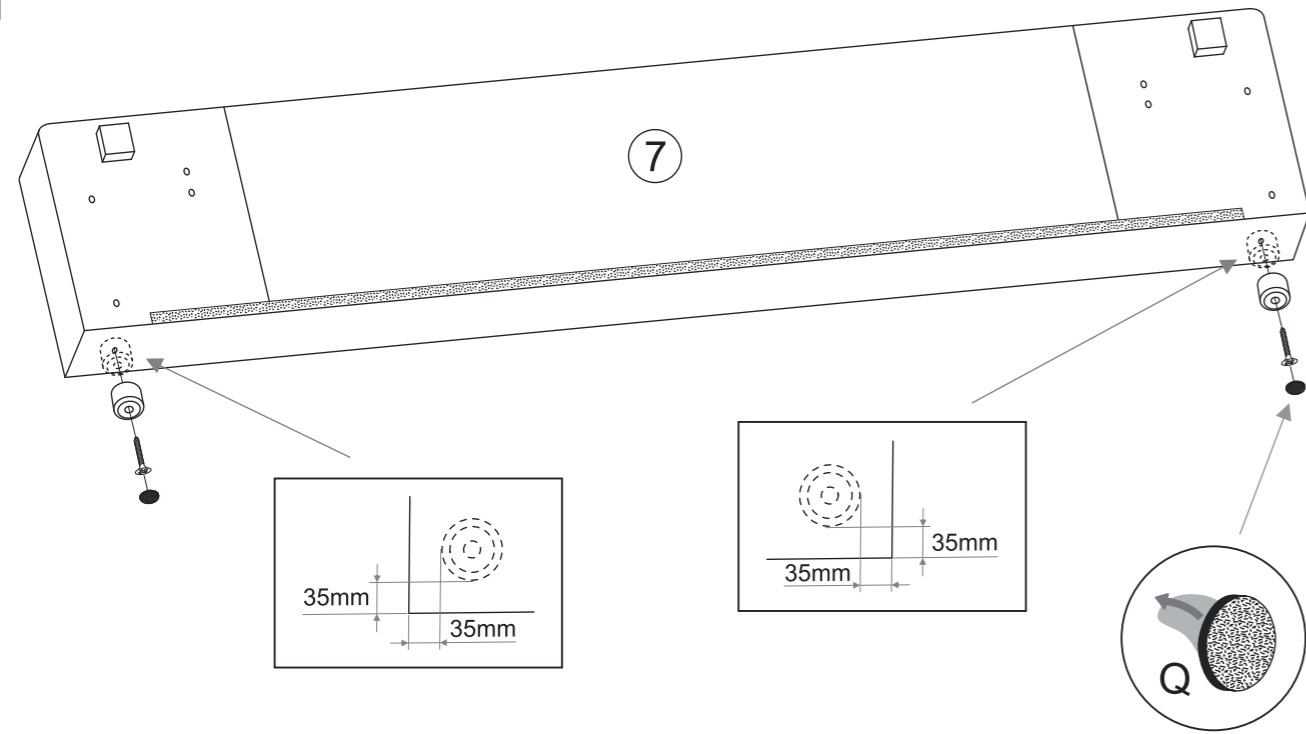

2

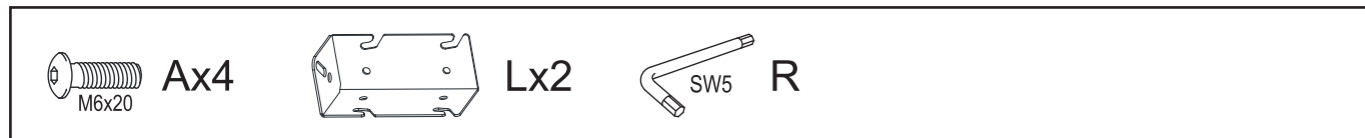
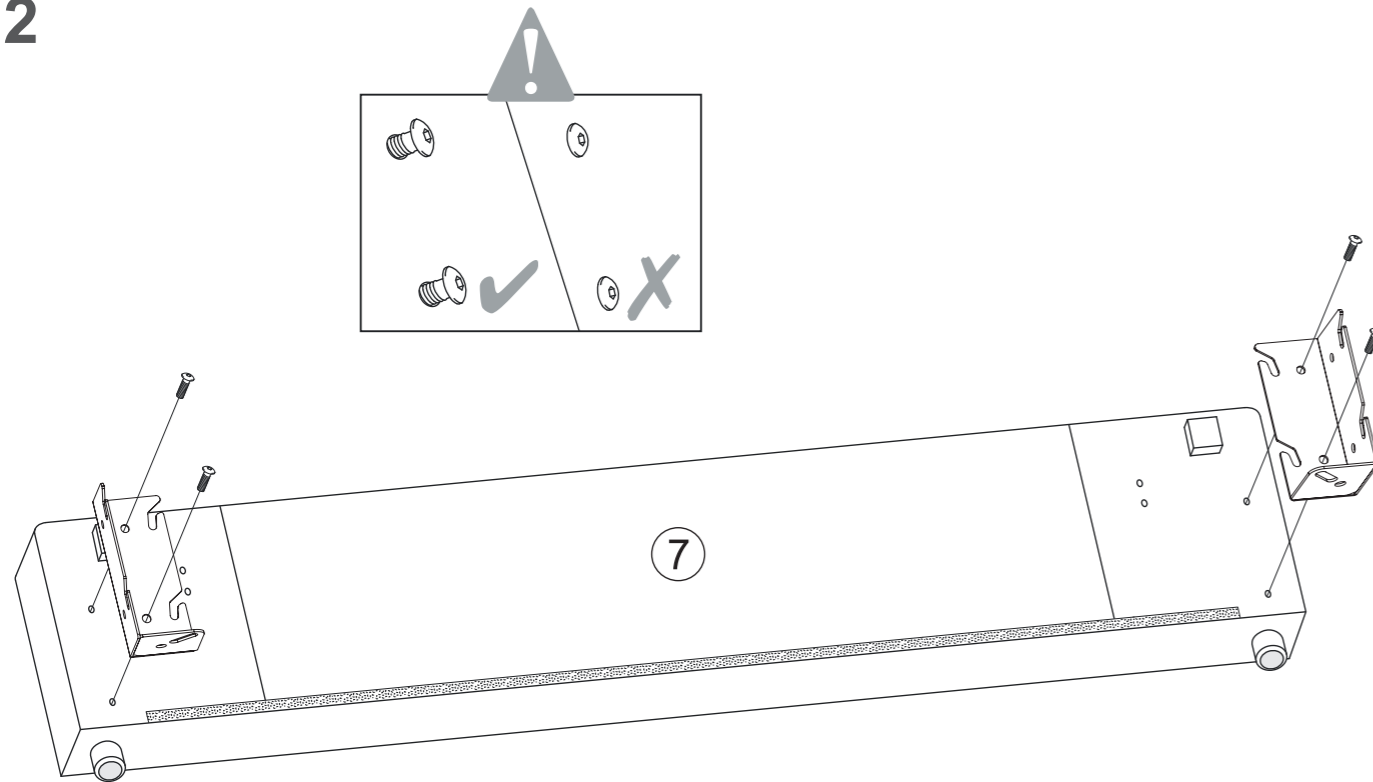

36

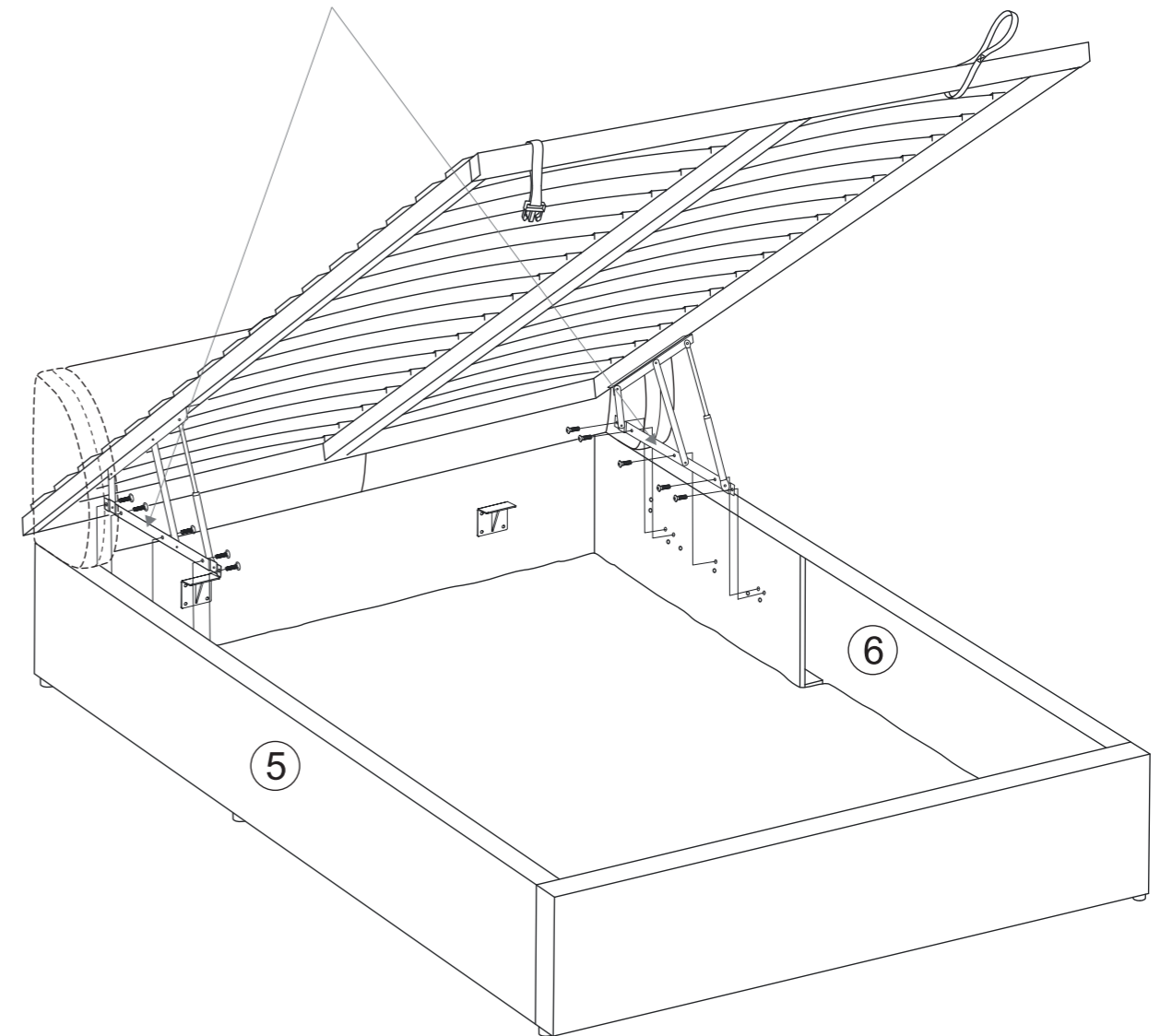
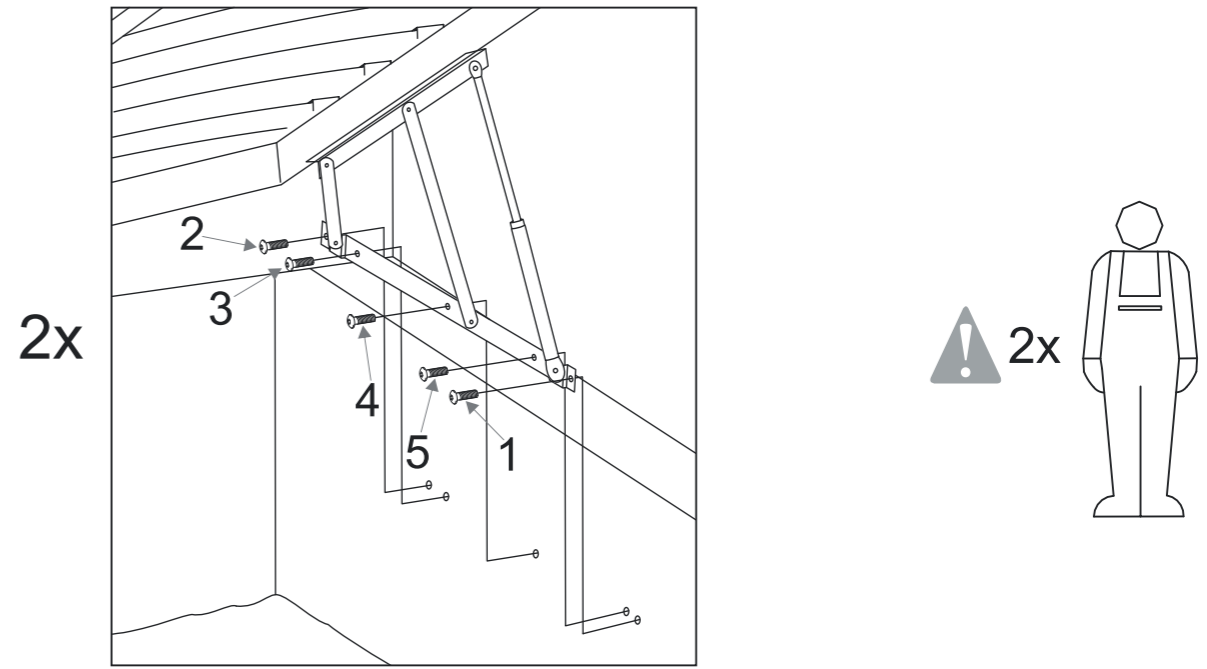

35a

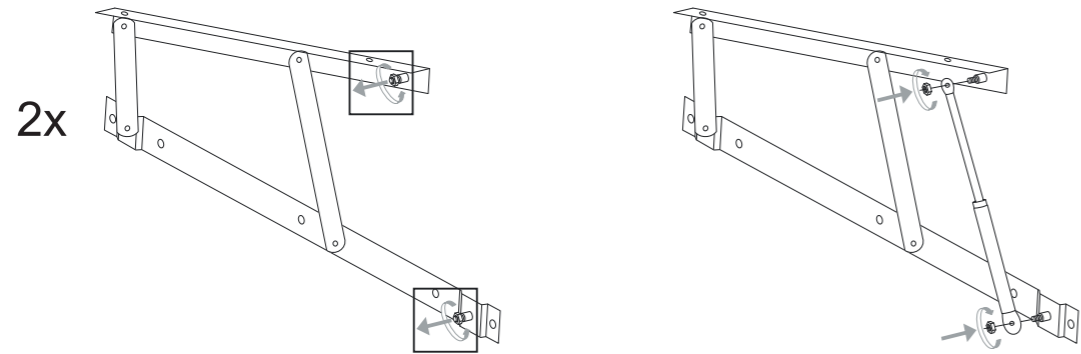
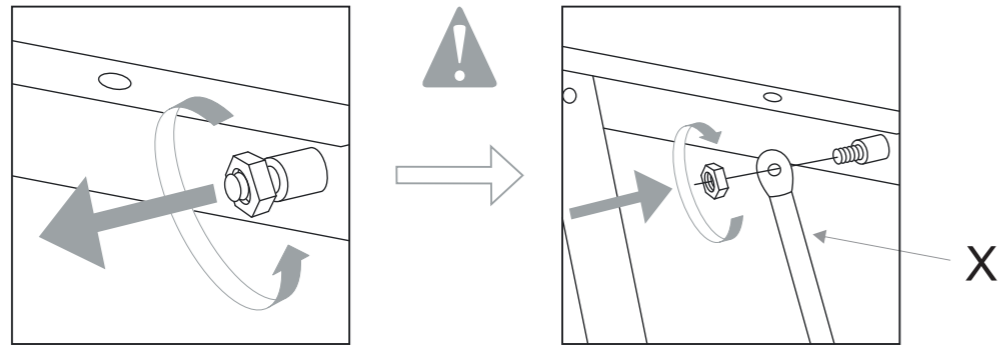

35b

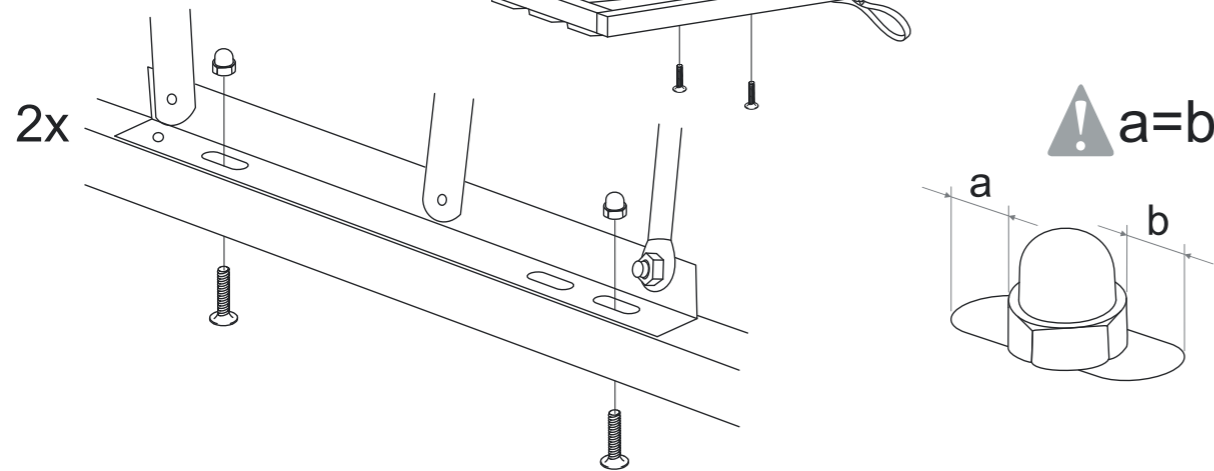
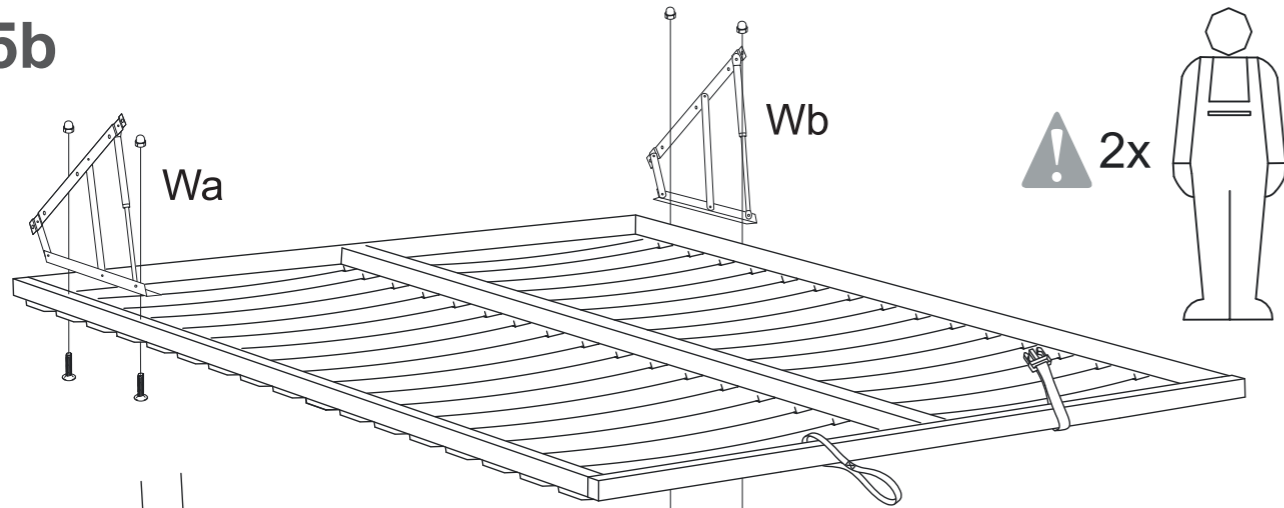

3

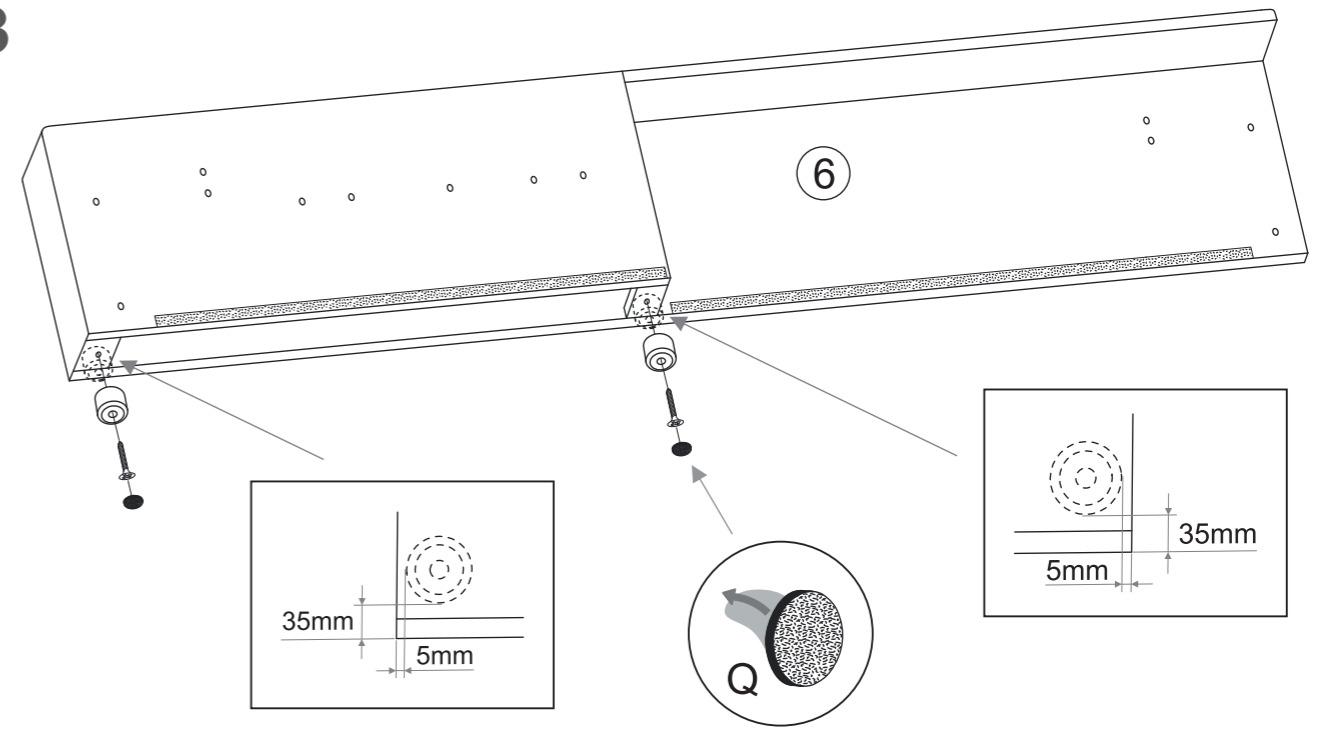

4

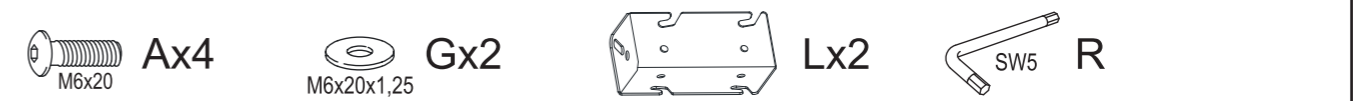
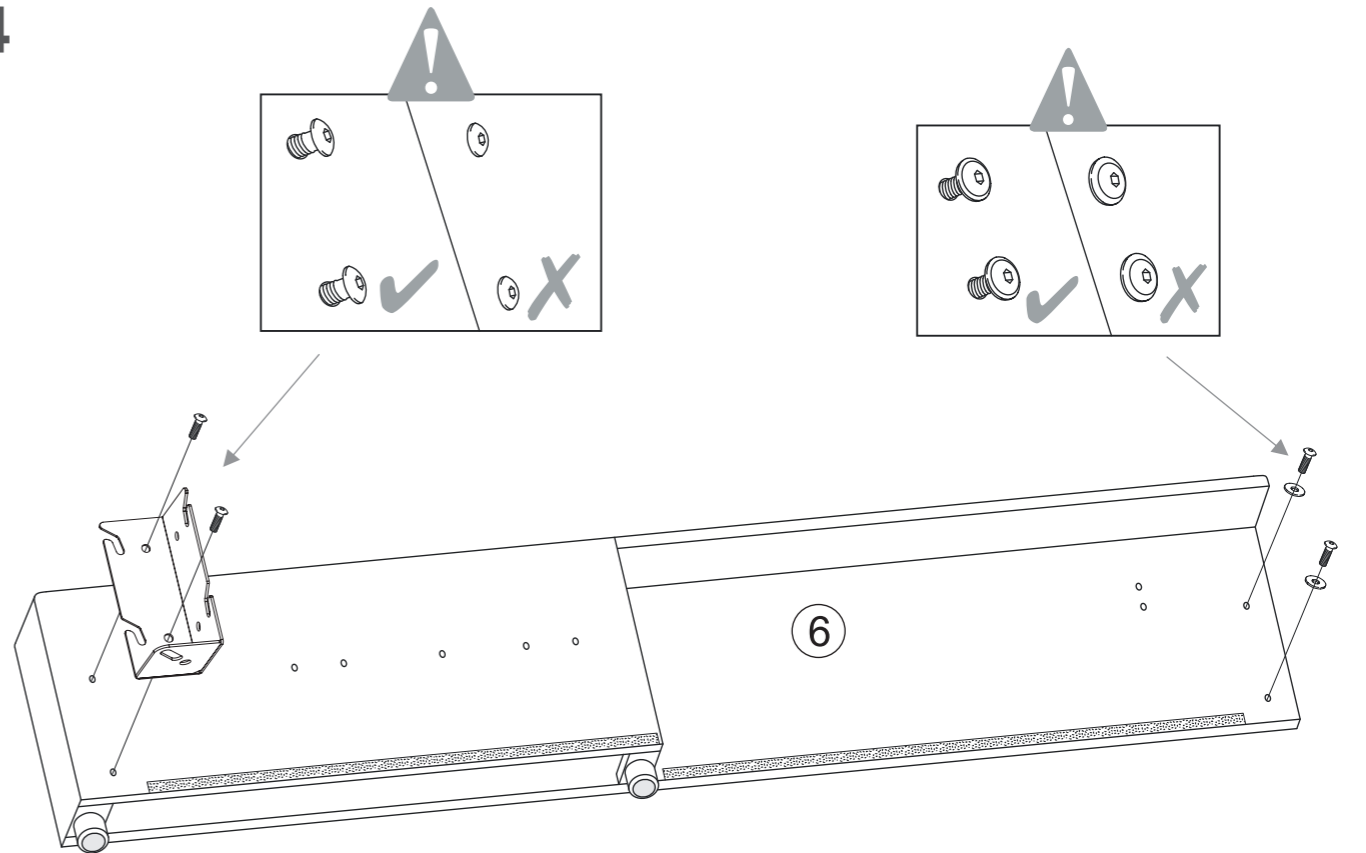

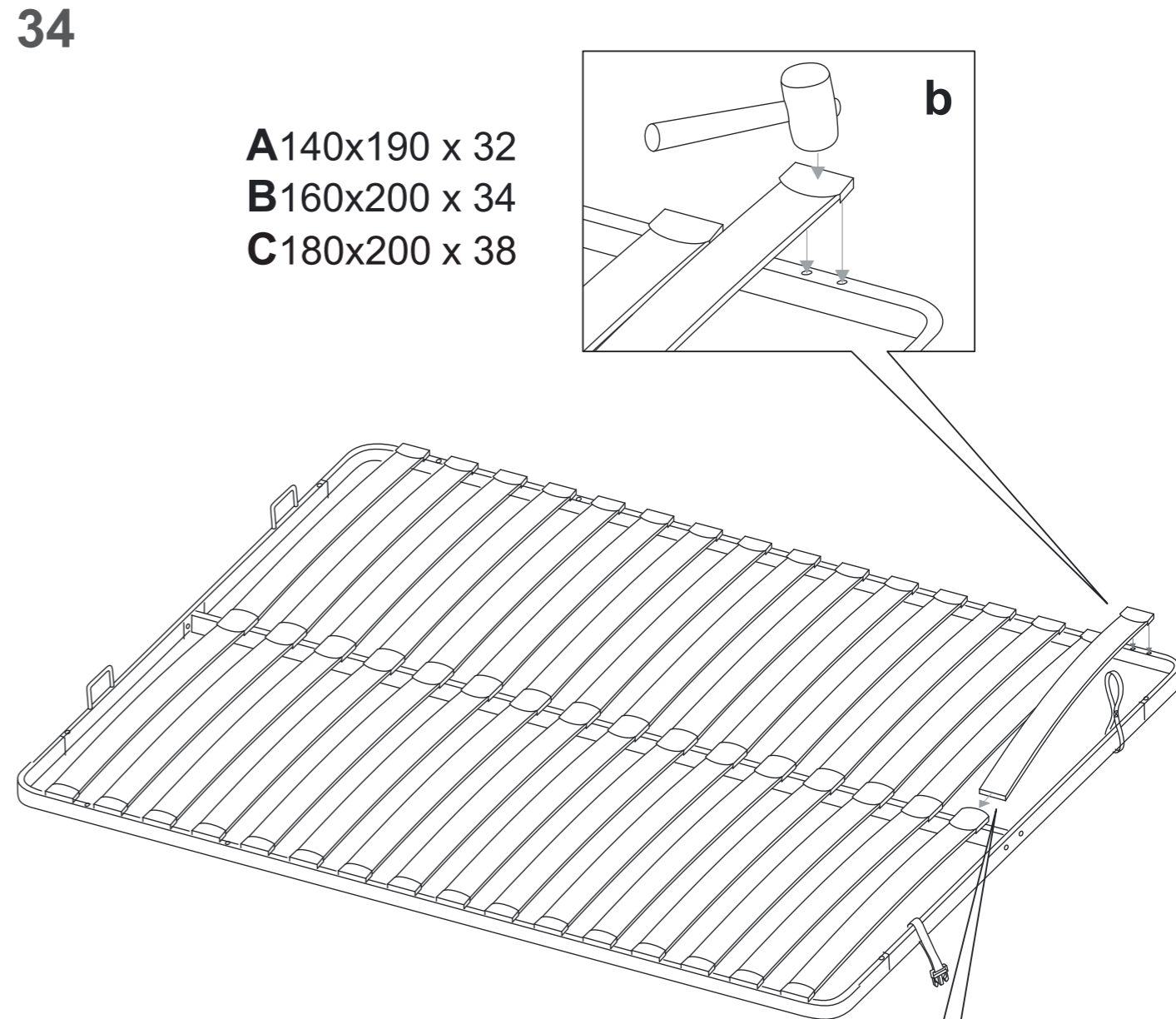
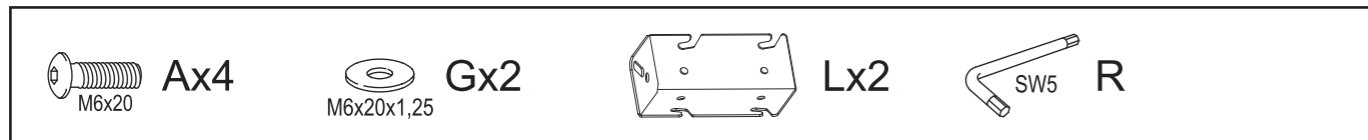
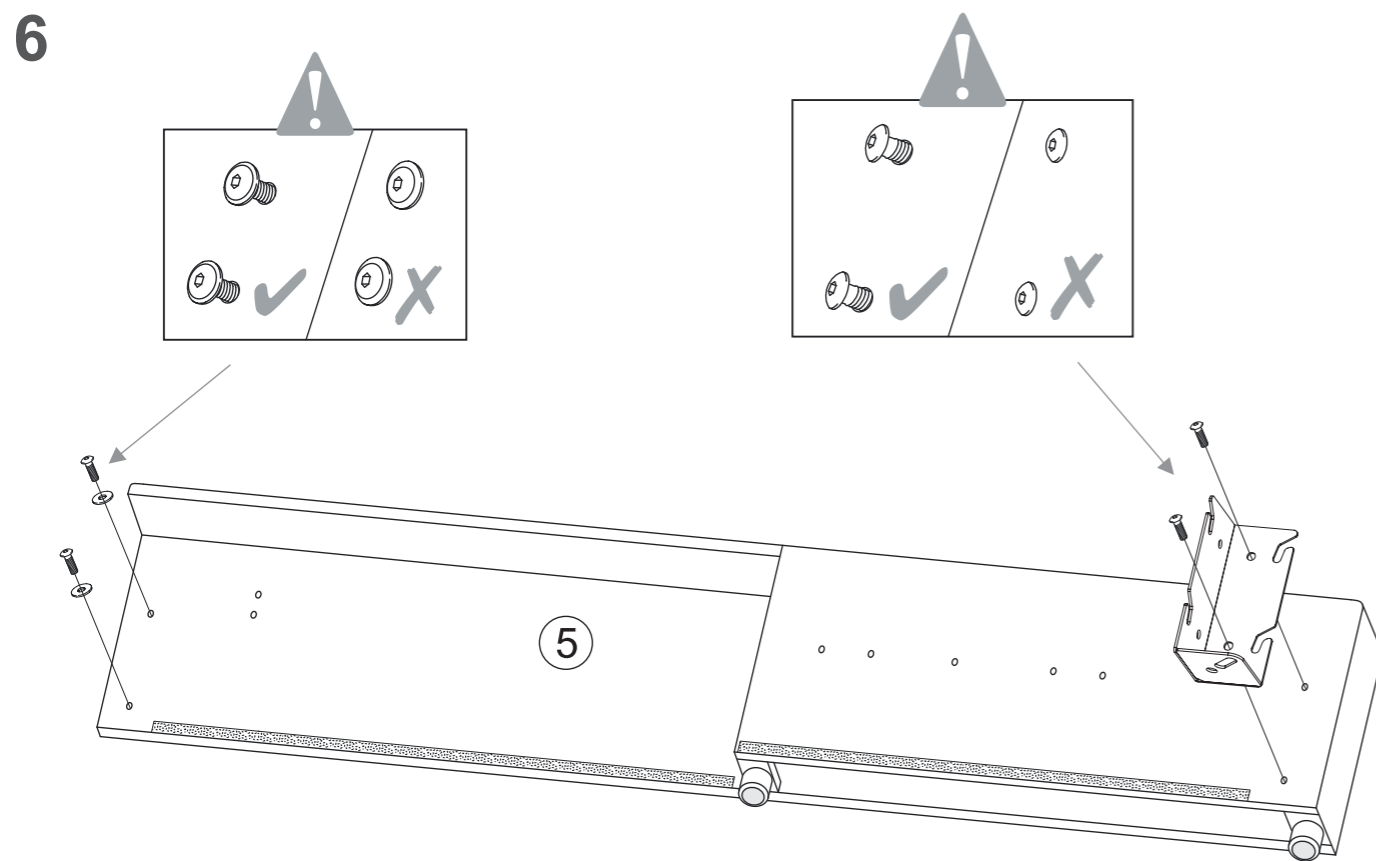
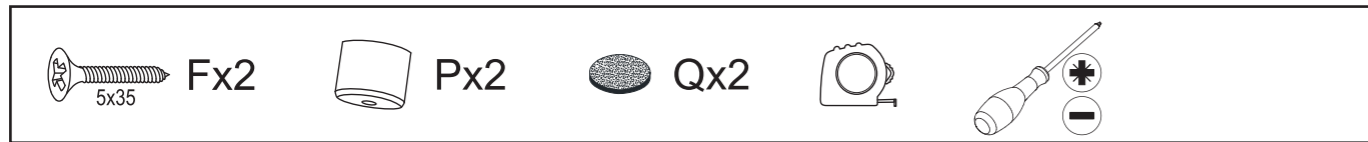
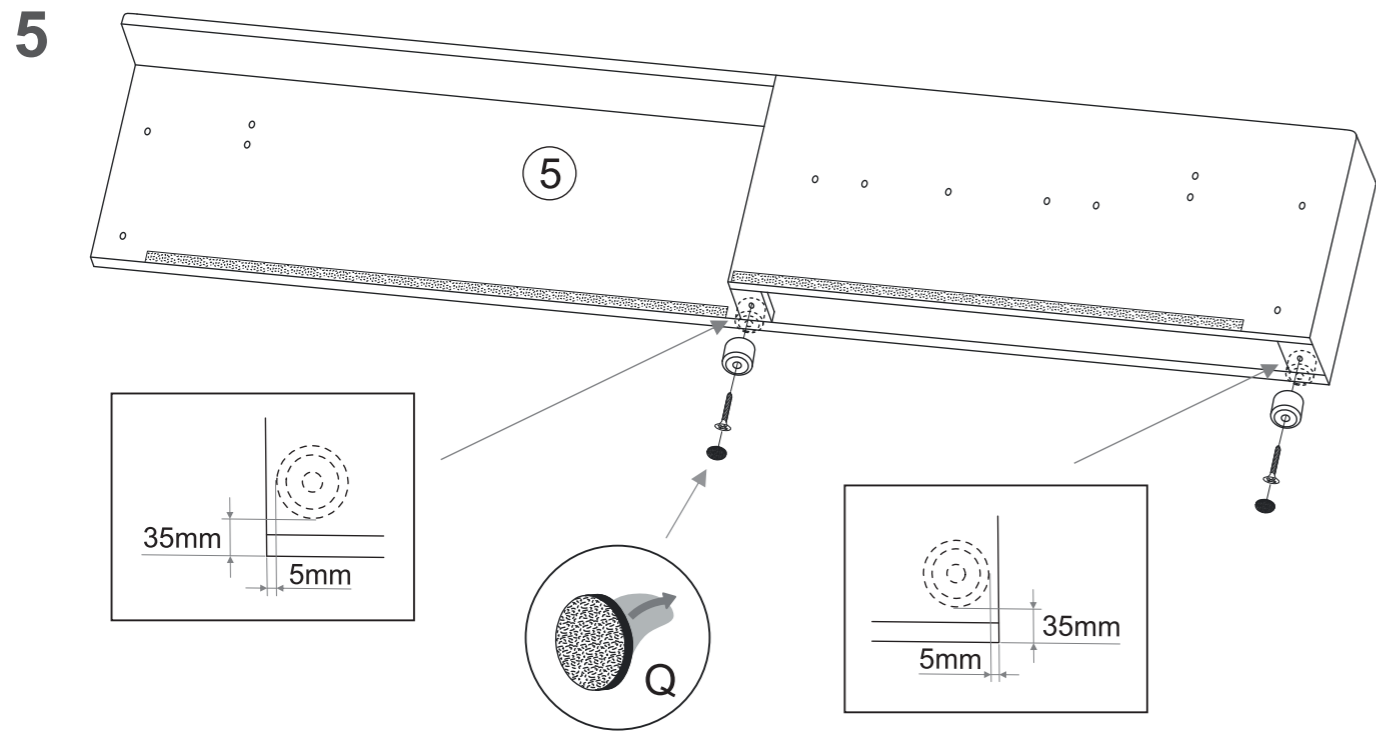

A140x190 x 32
B160x200 x 34
C180x200 x 38

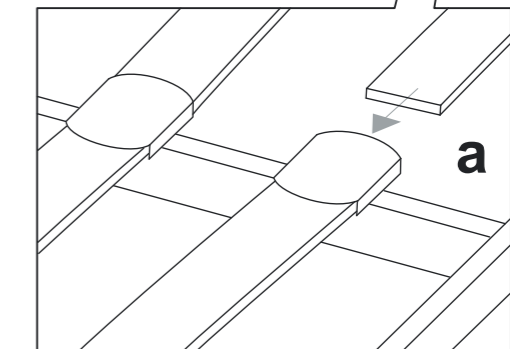

A140x190 x 32
B160x200 x 34
C180x200 x 38



32

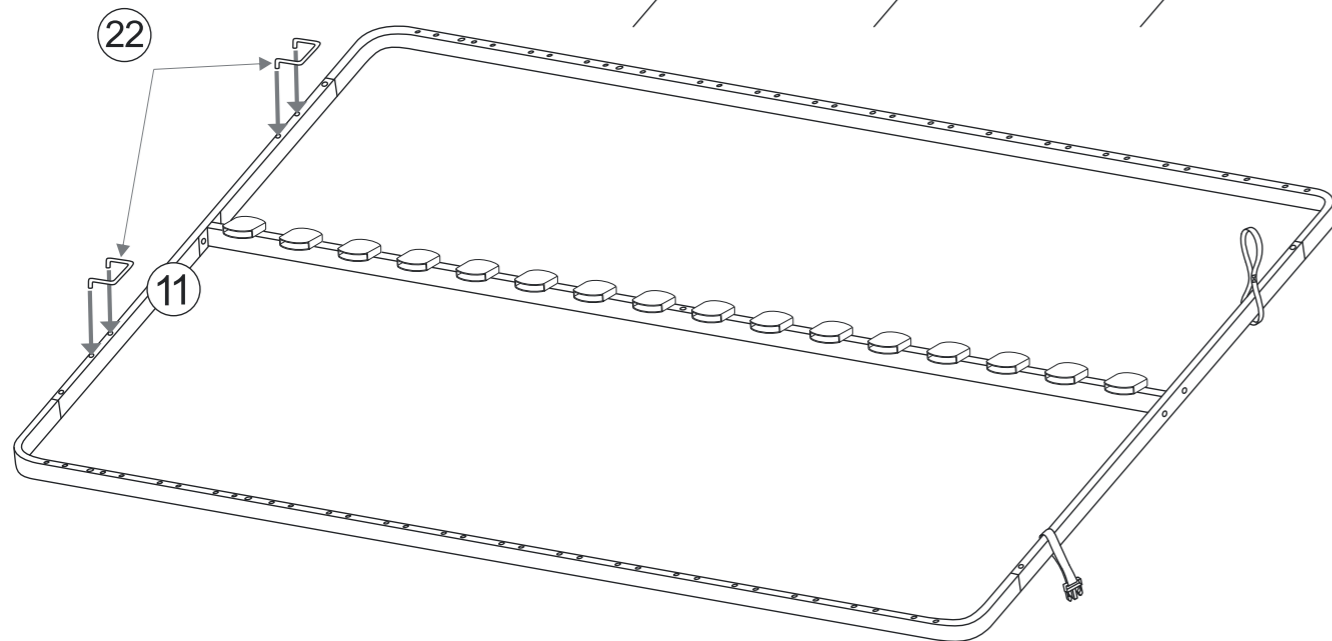
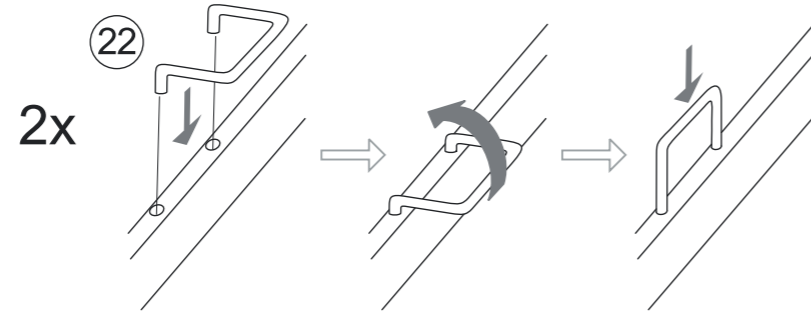

33

! A 140x190

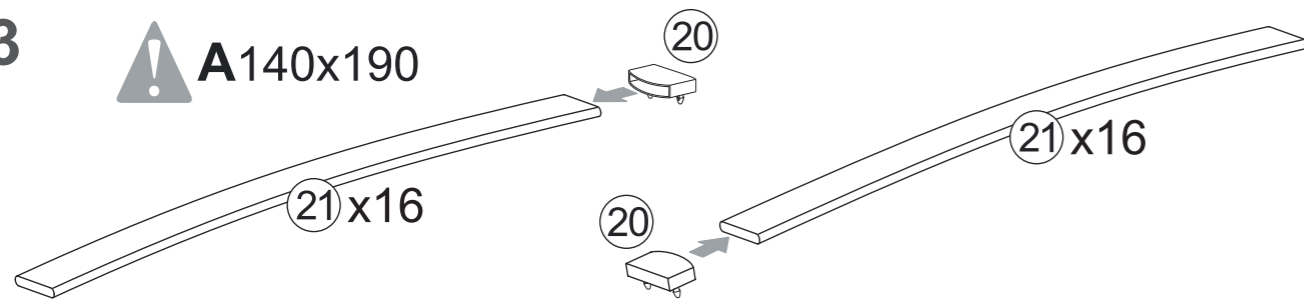

! B 160x200

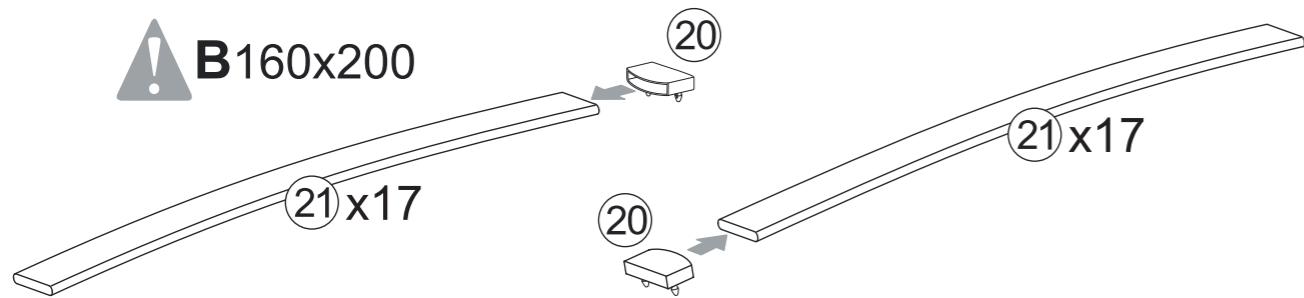

! C 180x200

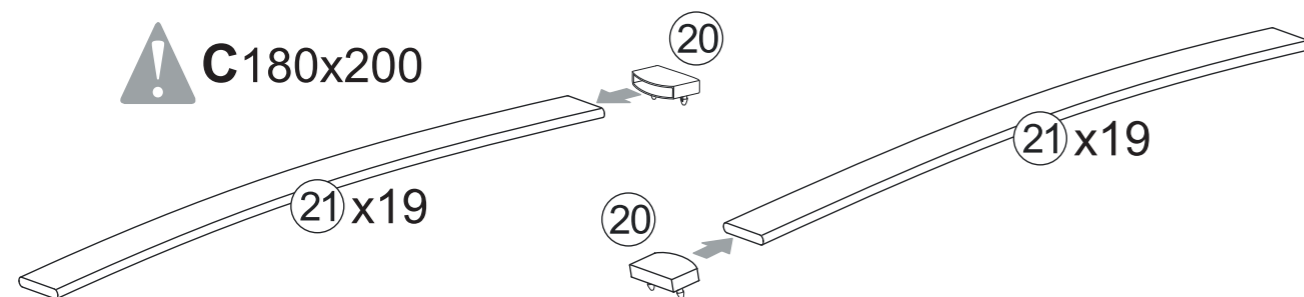

7

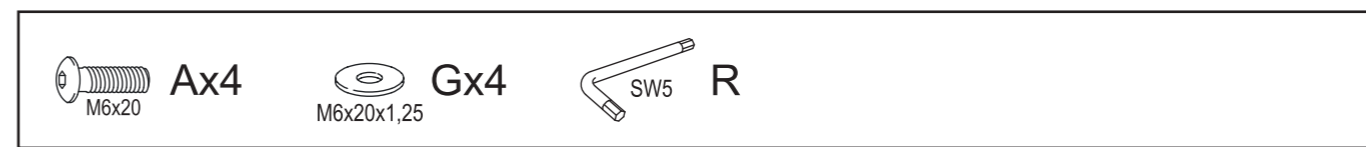
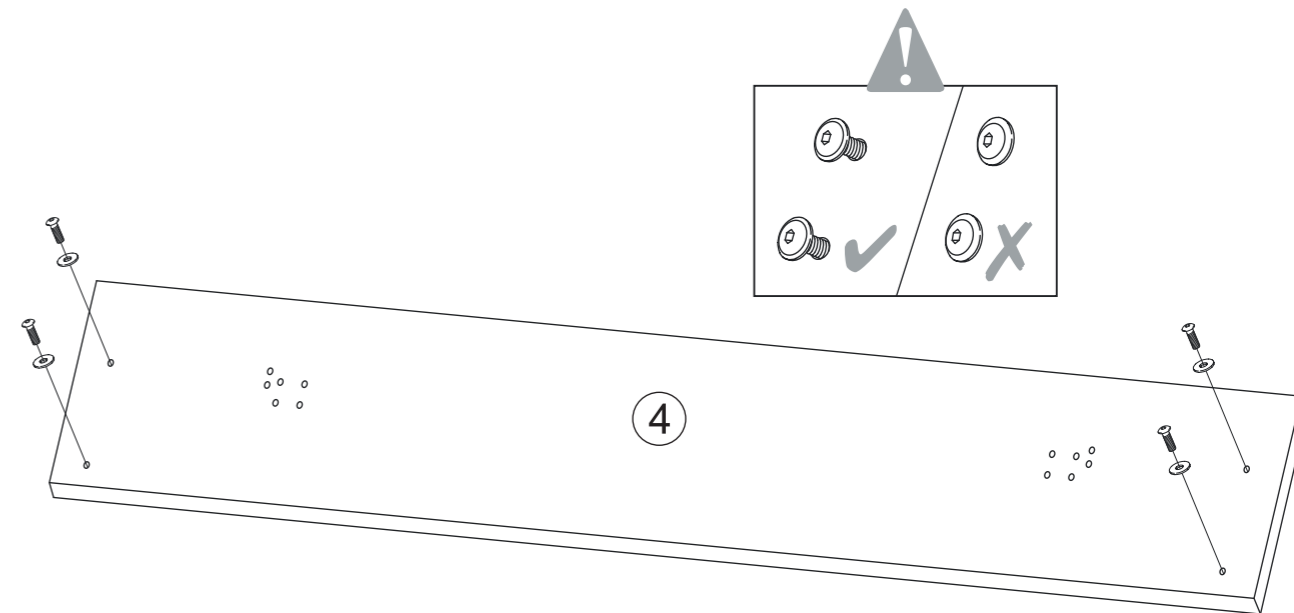

! Si vous avez acheté l'option sommier, allez directement à l'étape 17

8

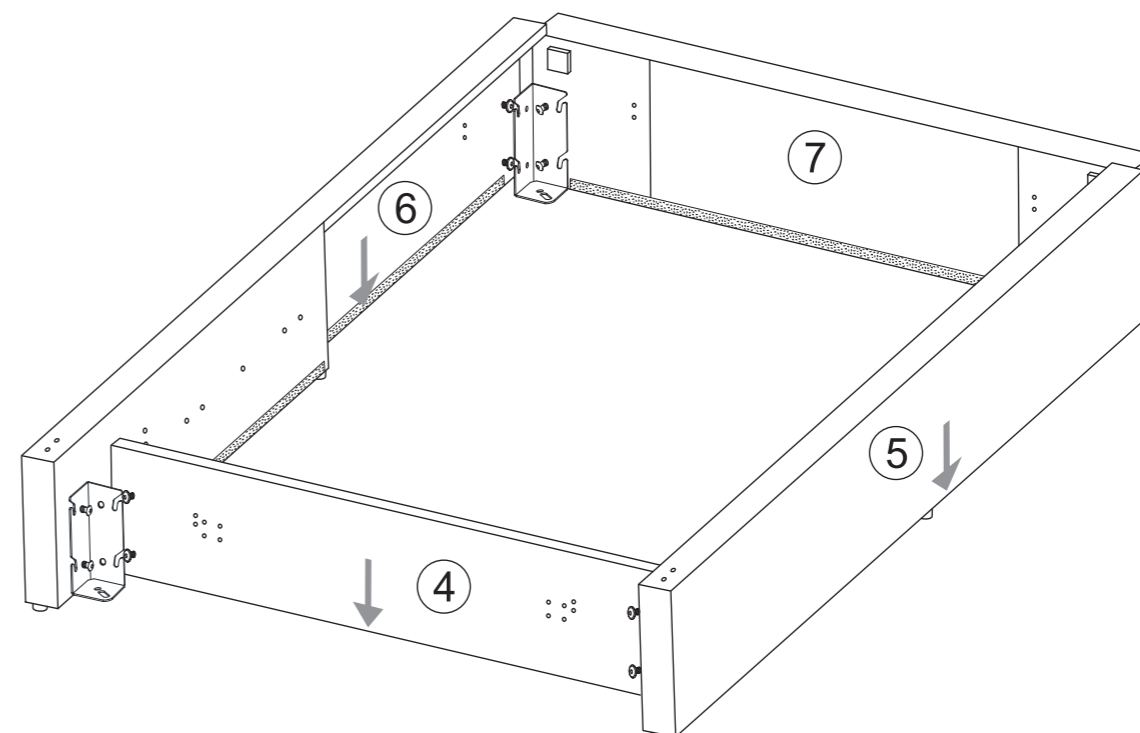
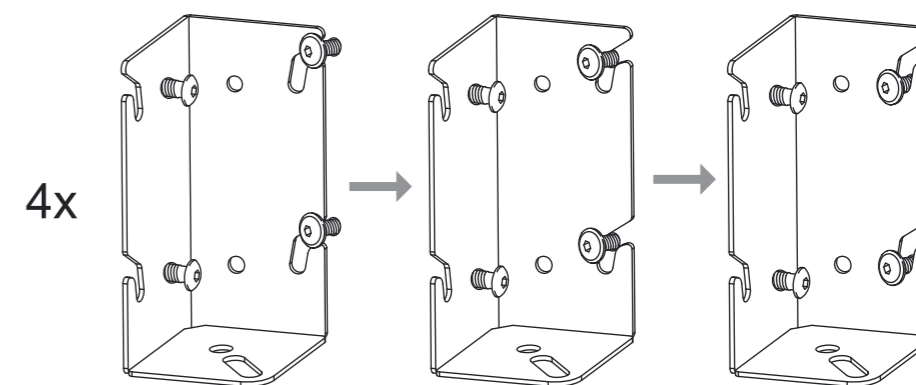

9

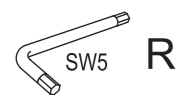
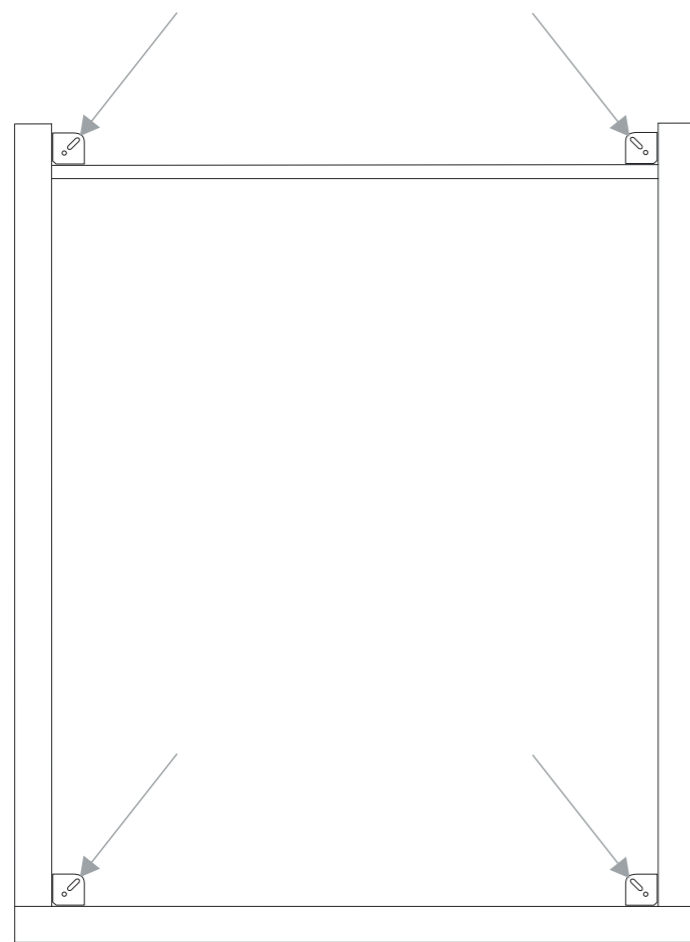
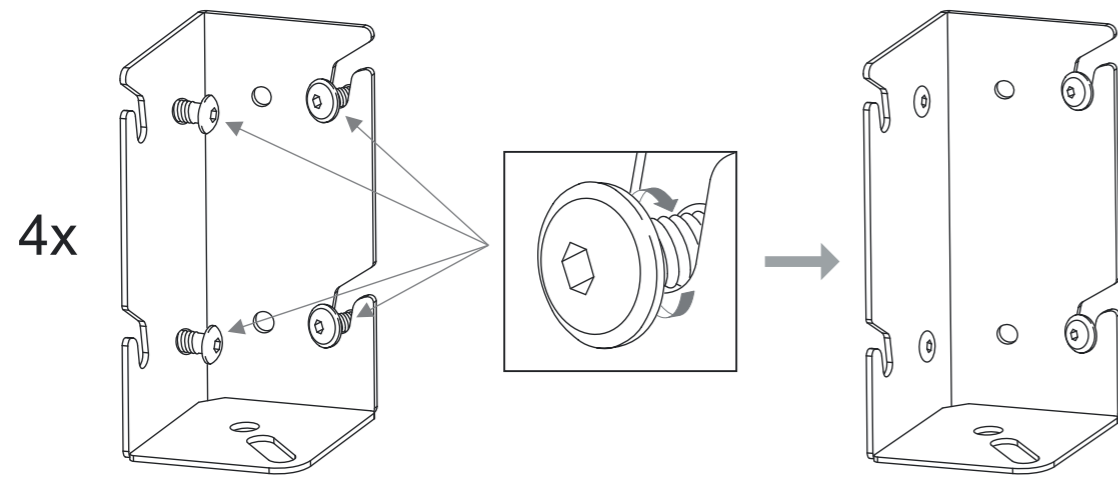

R

31

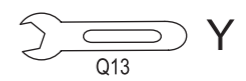
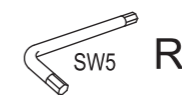
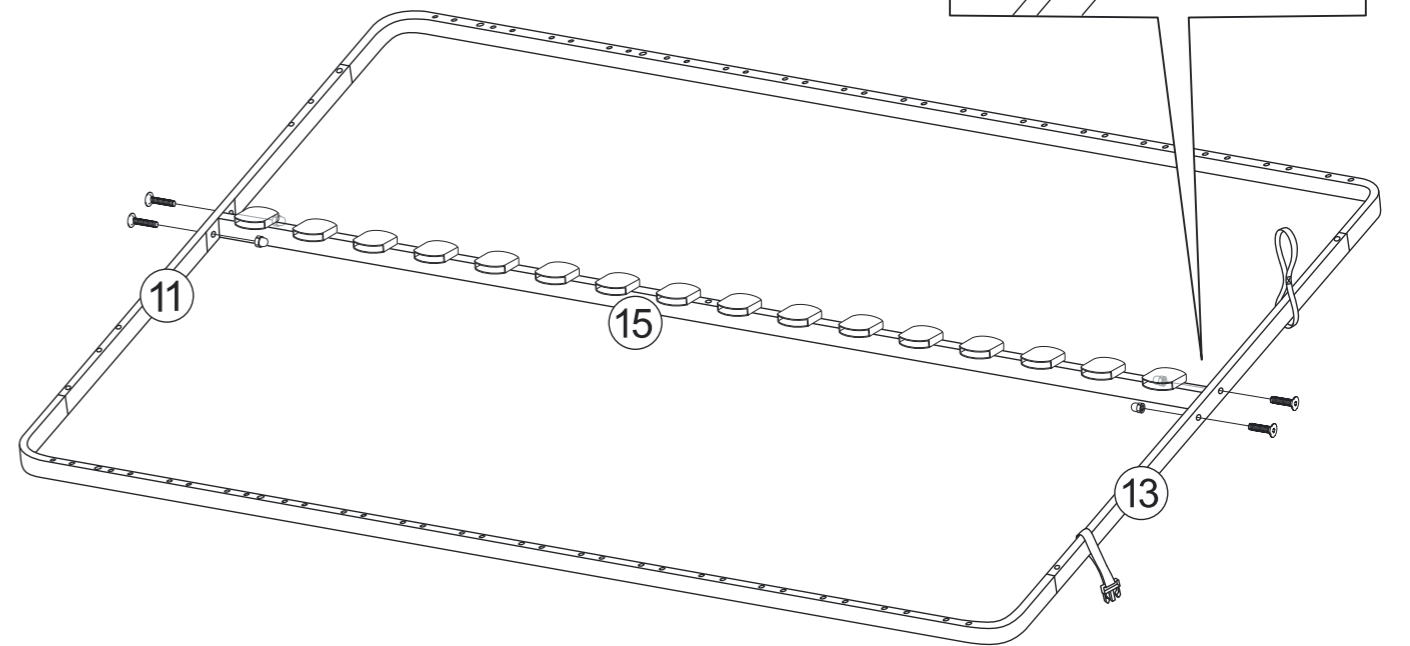
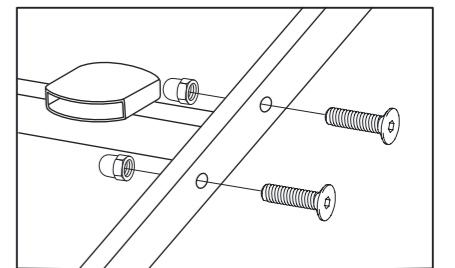
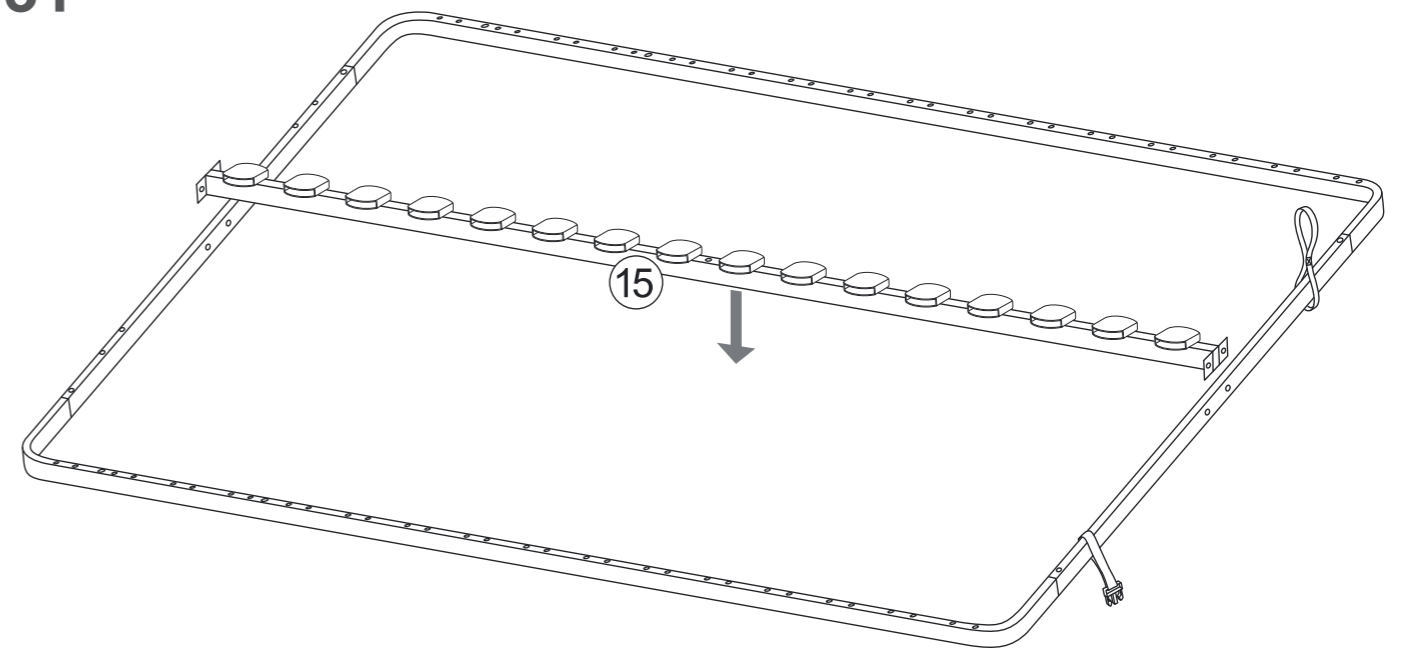

29

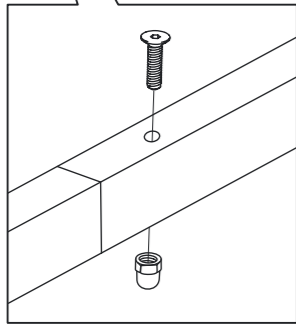
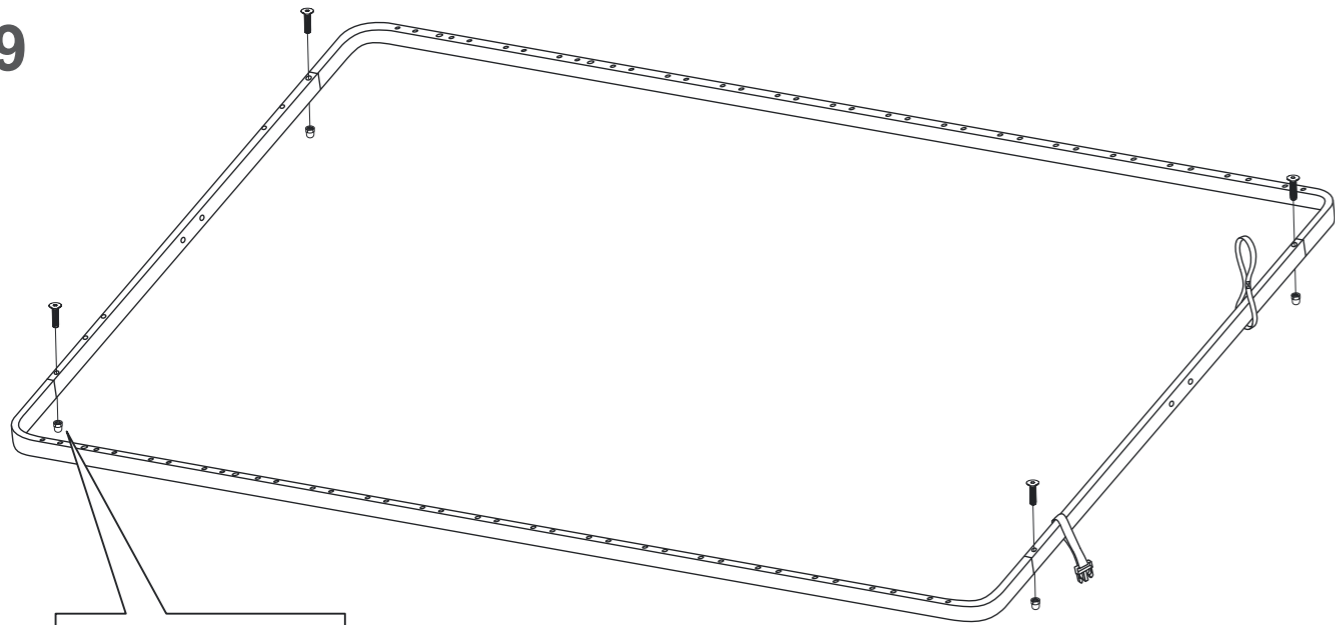

30



- A** 140x190 19 x 16
- B** 160x200 19 x 17
- C** 180x200 19 x 19

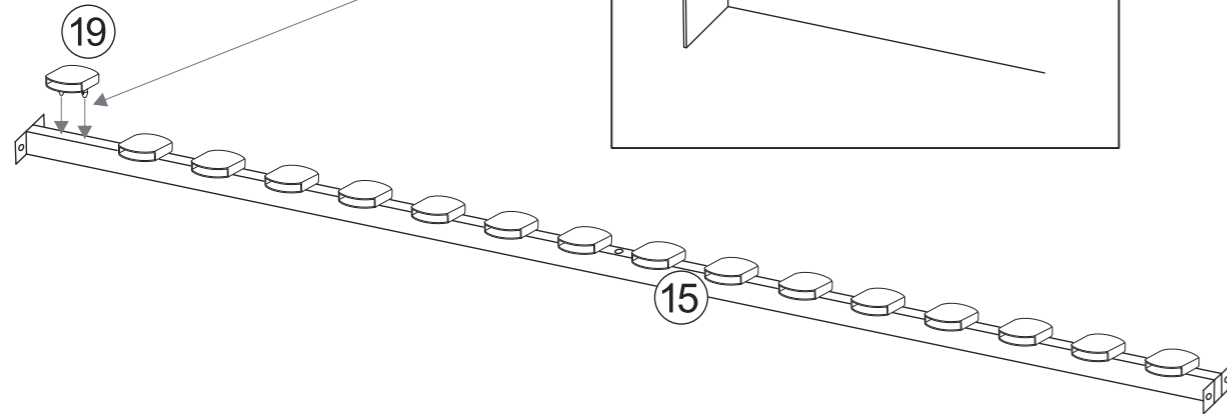
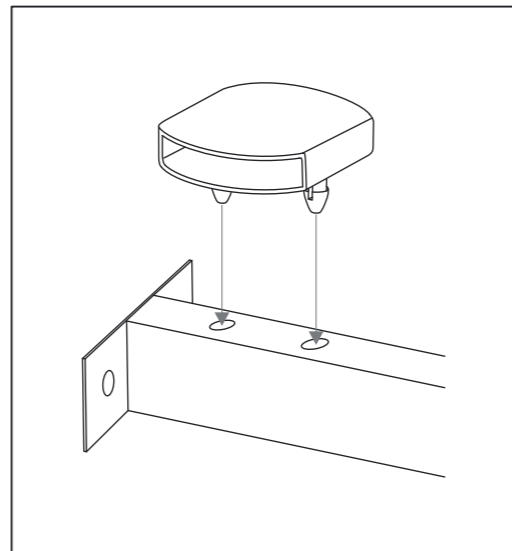

10

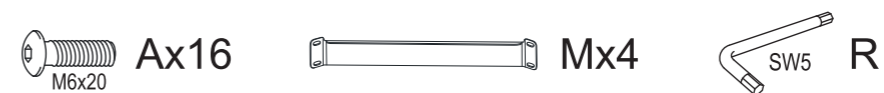
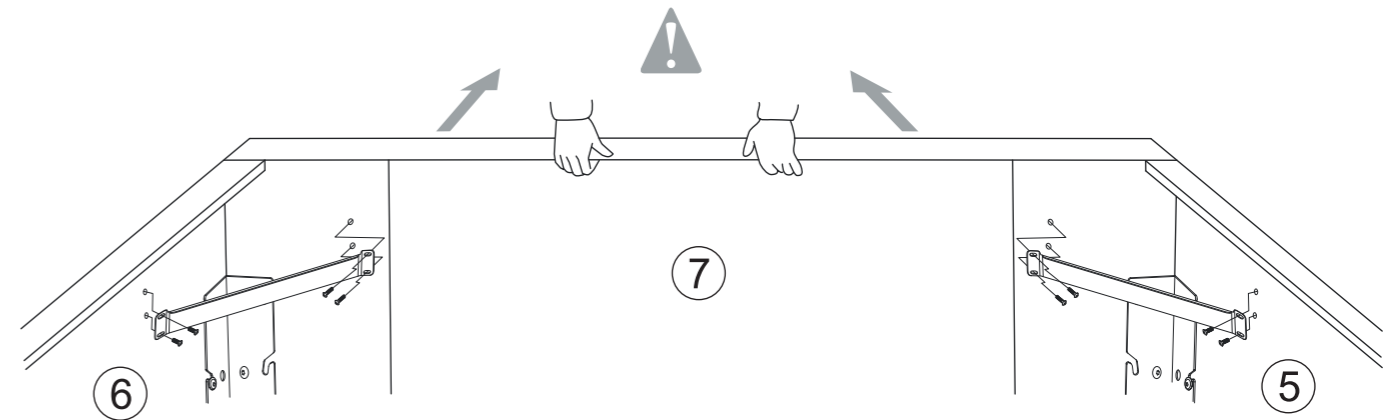
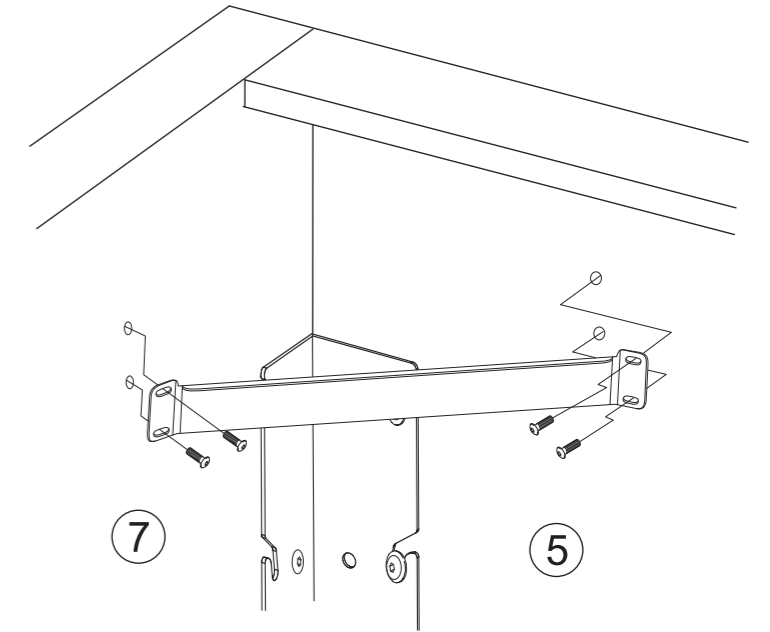
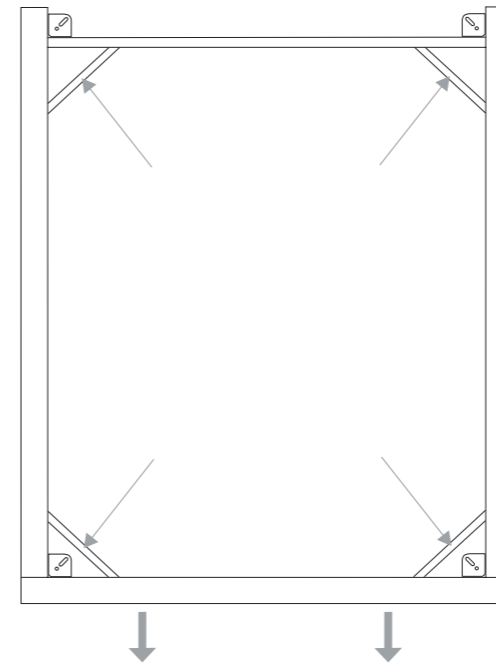
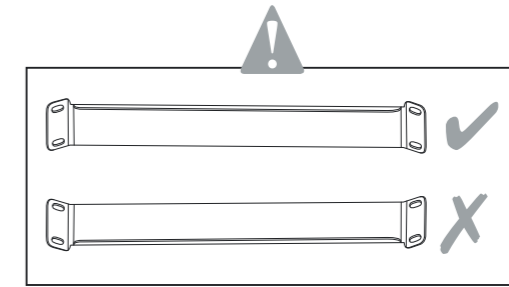

11

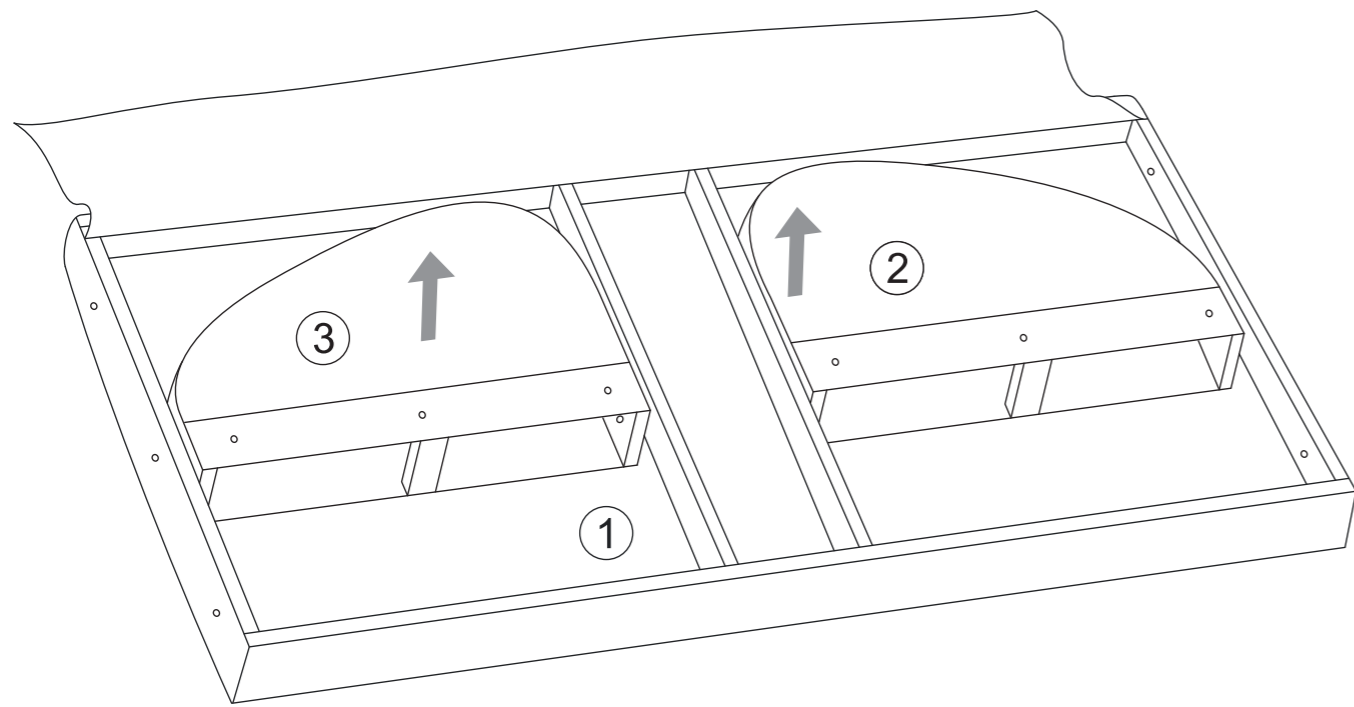
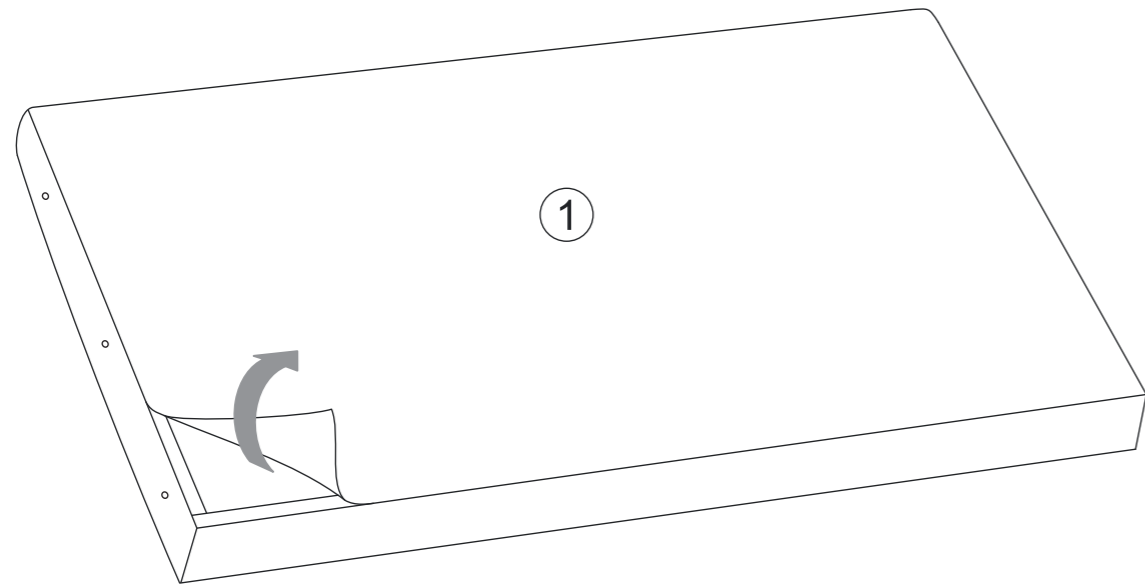

27 a

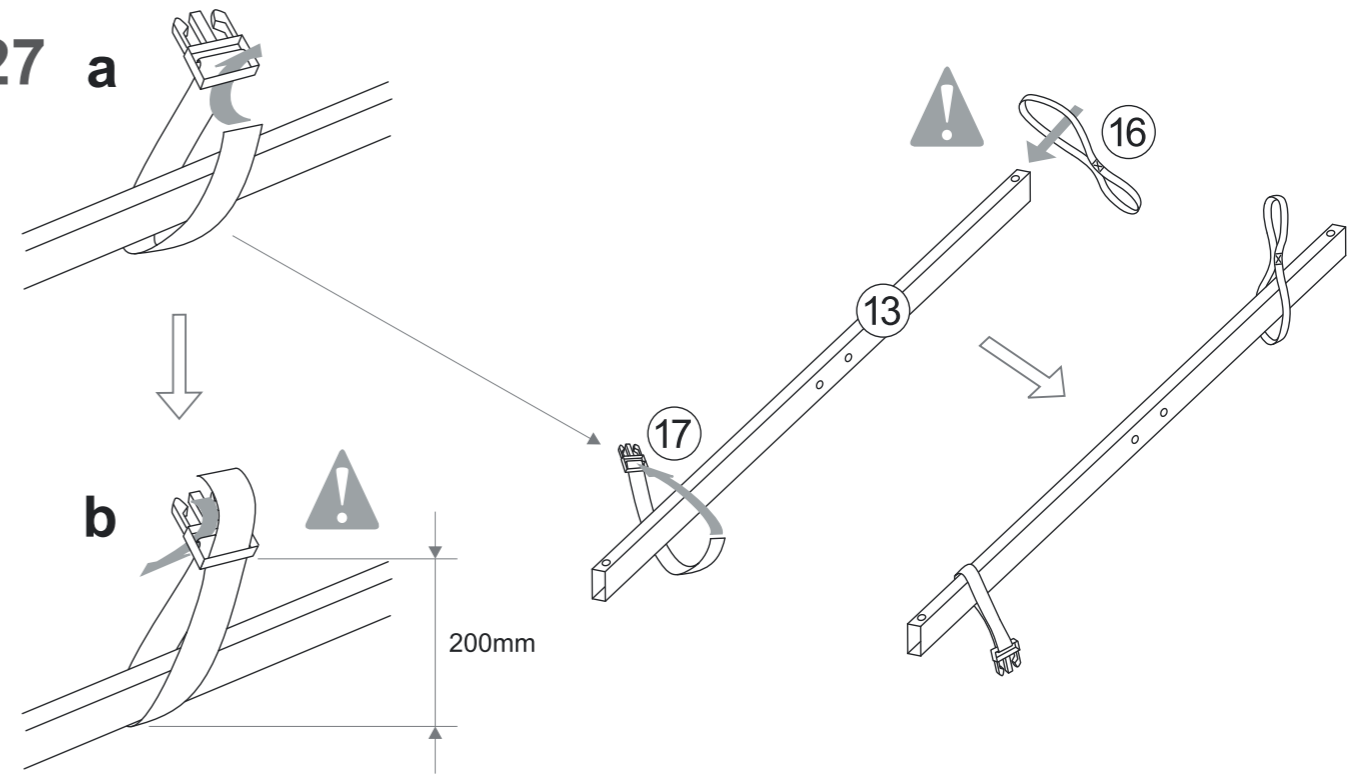

28

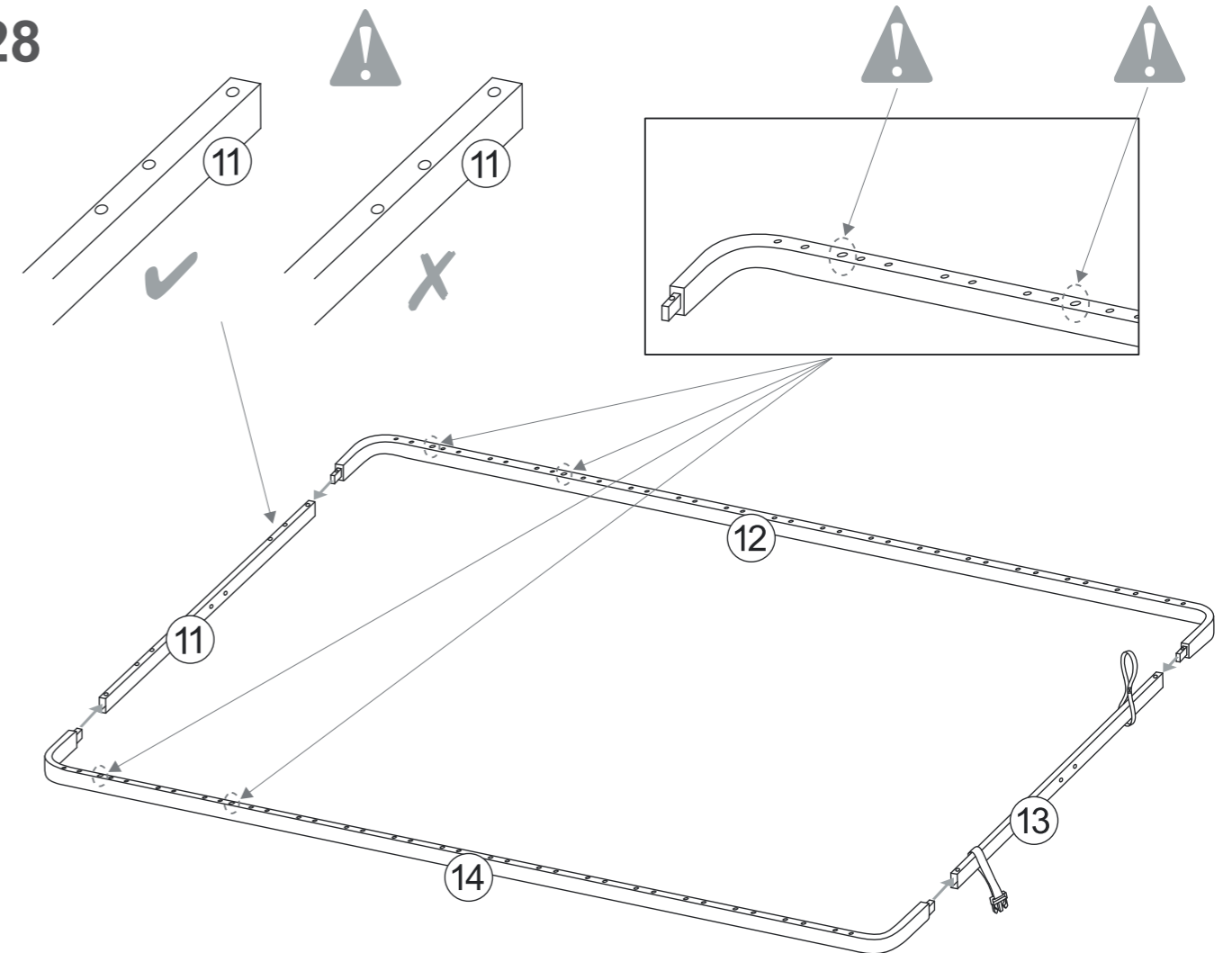

C180x200

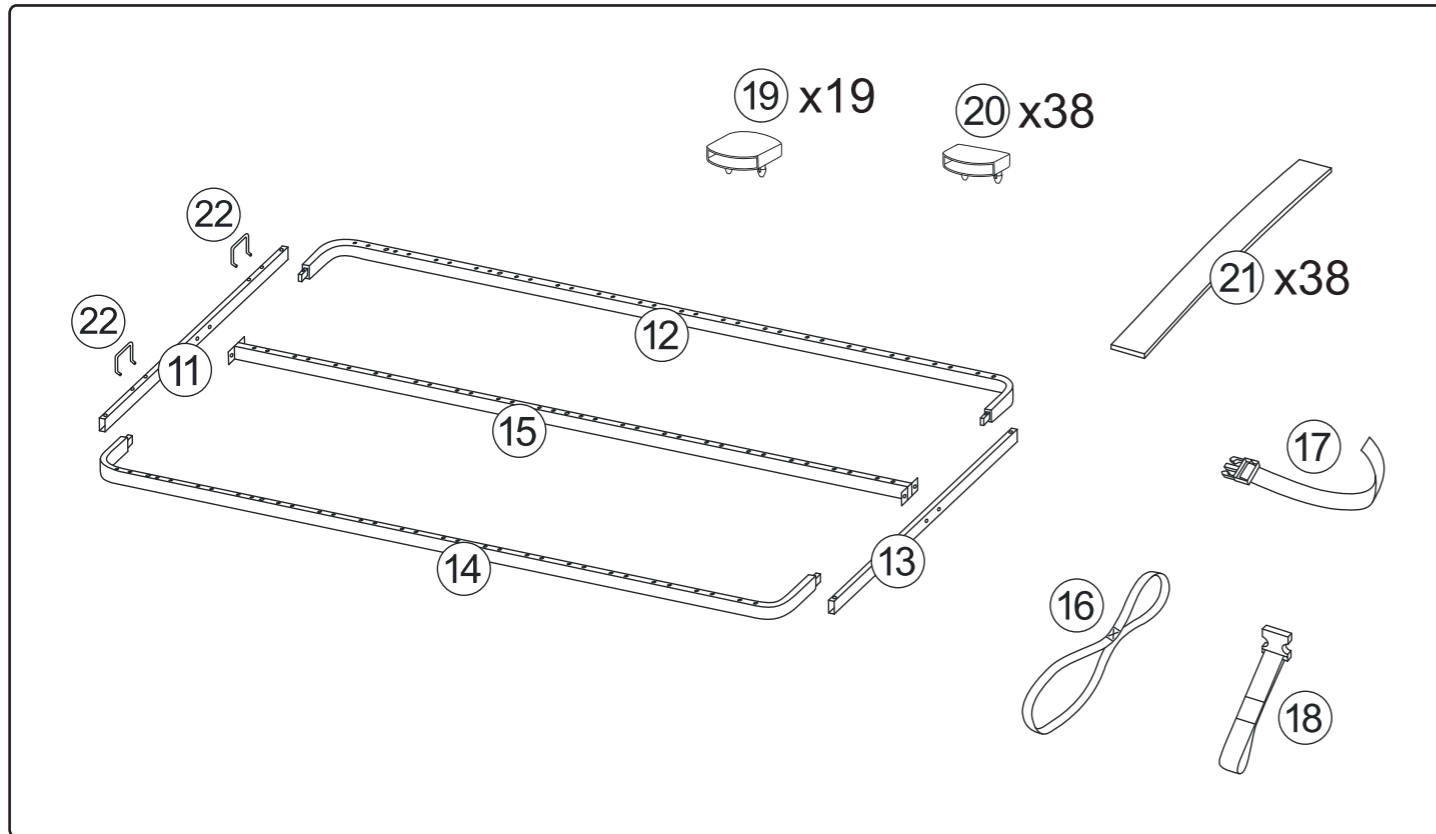

C3"

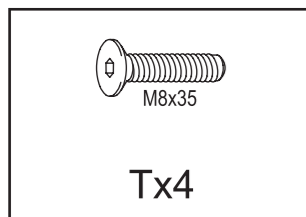

Tx4

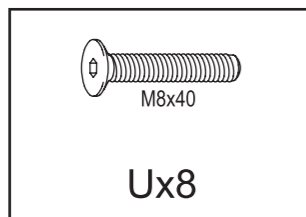

Ux8

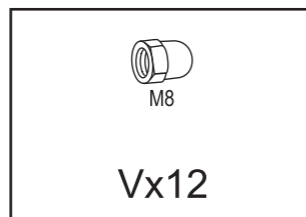

Vx12

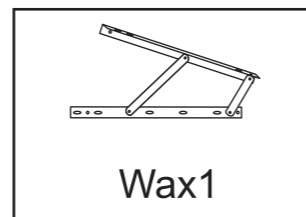

Wax1

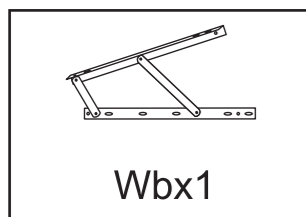

Wbx1

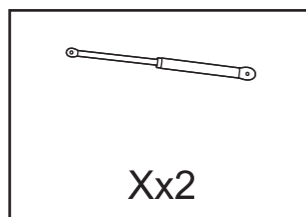

Xx2

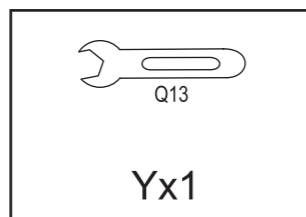

Yx1

12

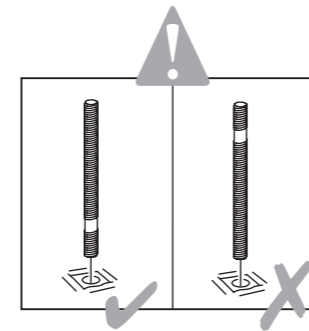

Dx6
M6x70/10/55

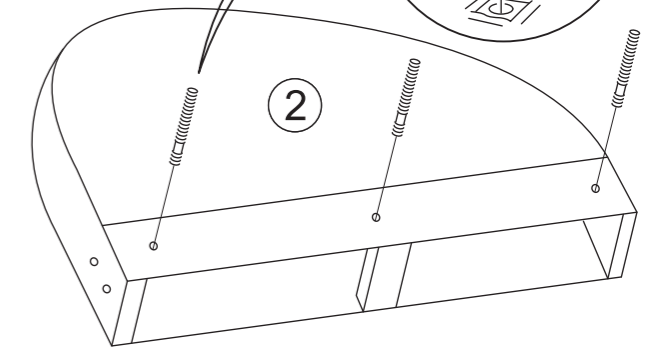
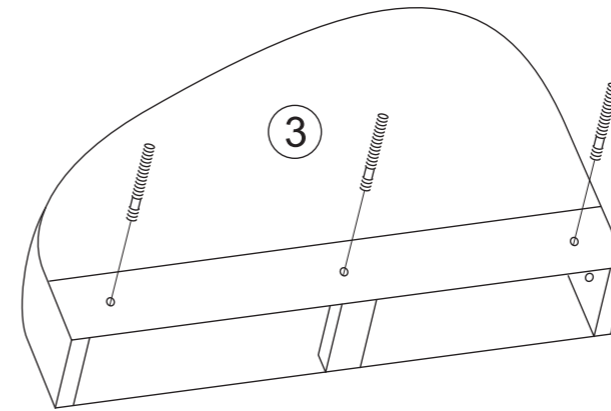
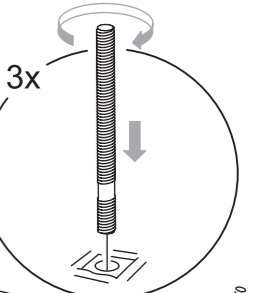

13

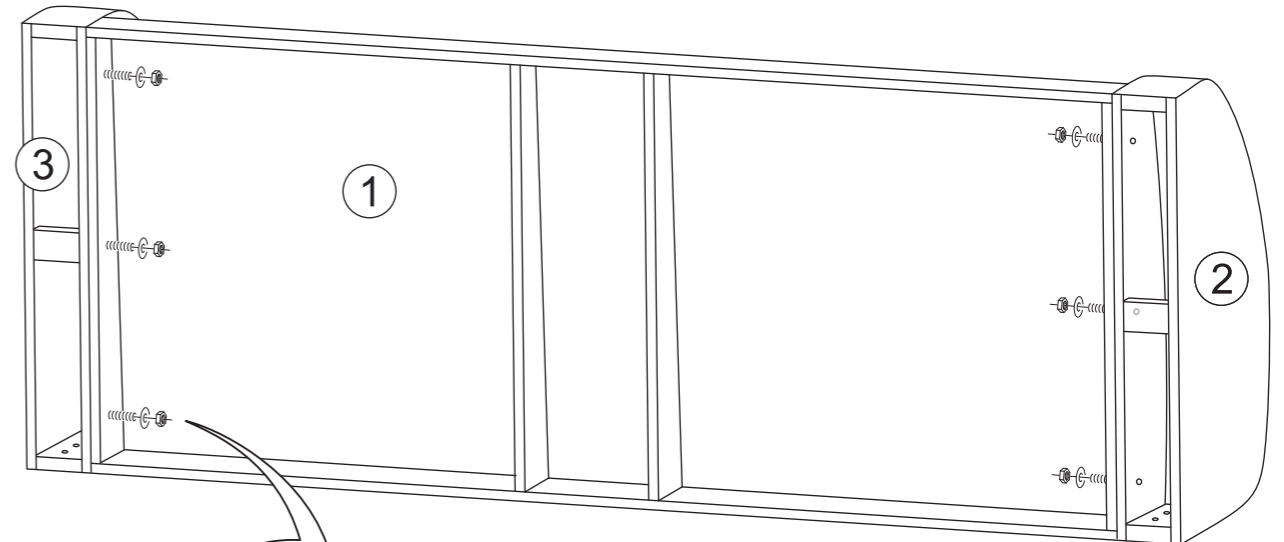

Gx6
M6x20x1,25

Jx6
M6

Sx1
Q13

14

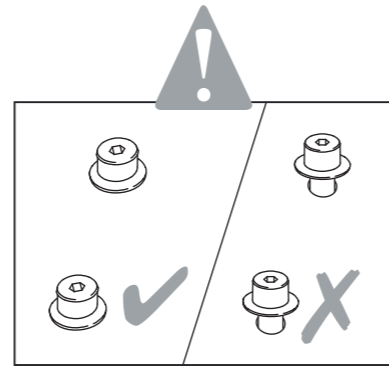
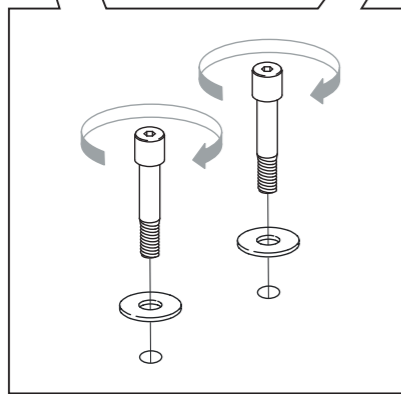
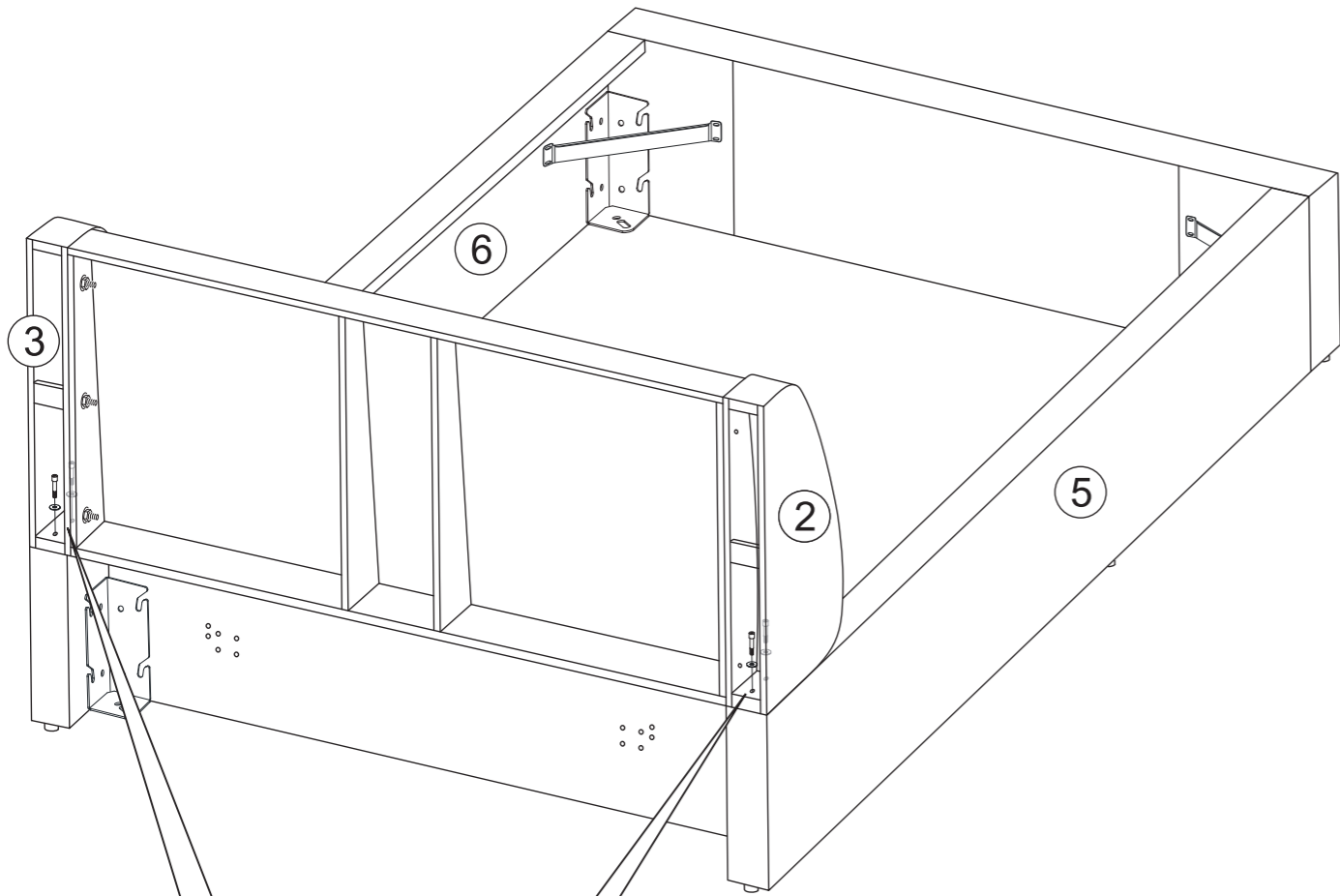

A140x190

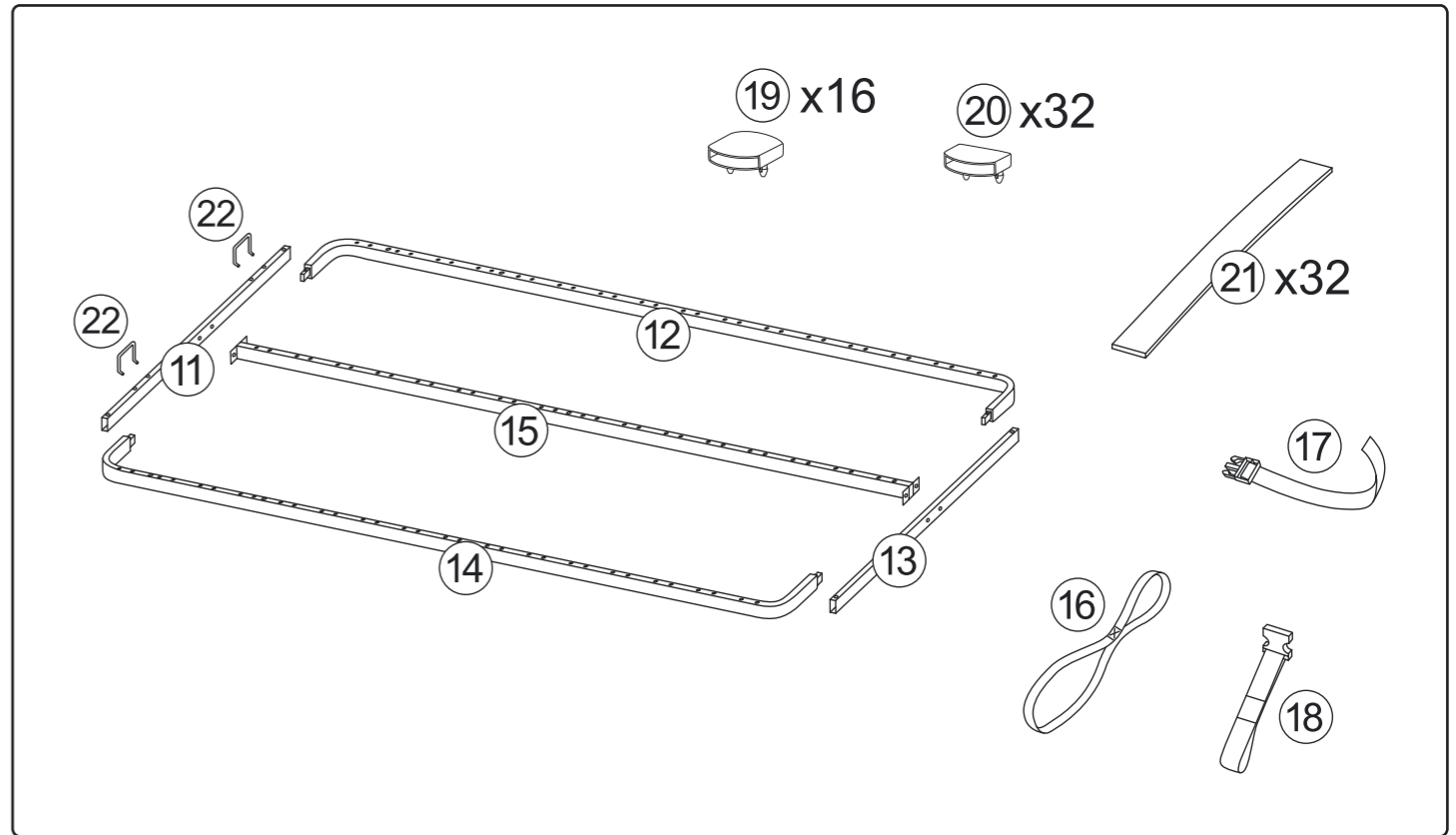

C3

B160x200

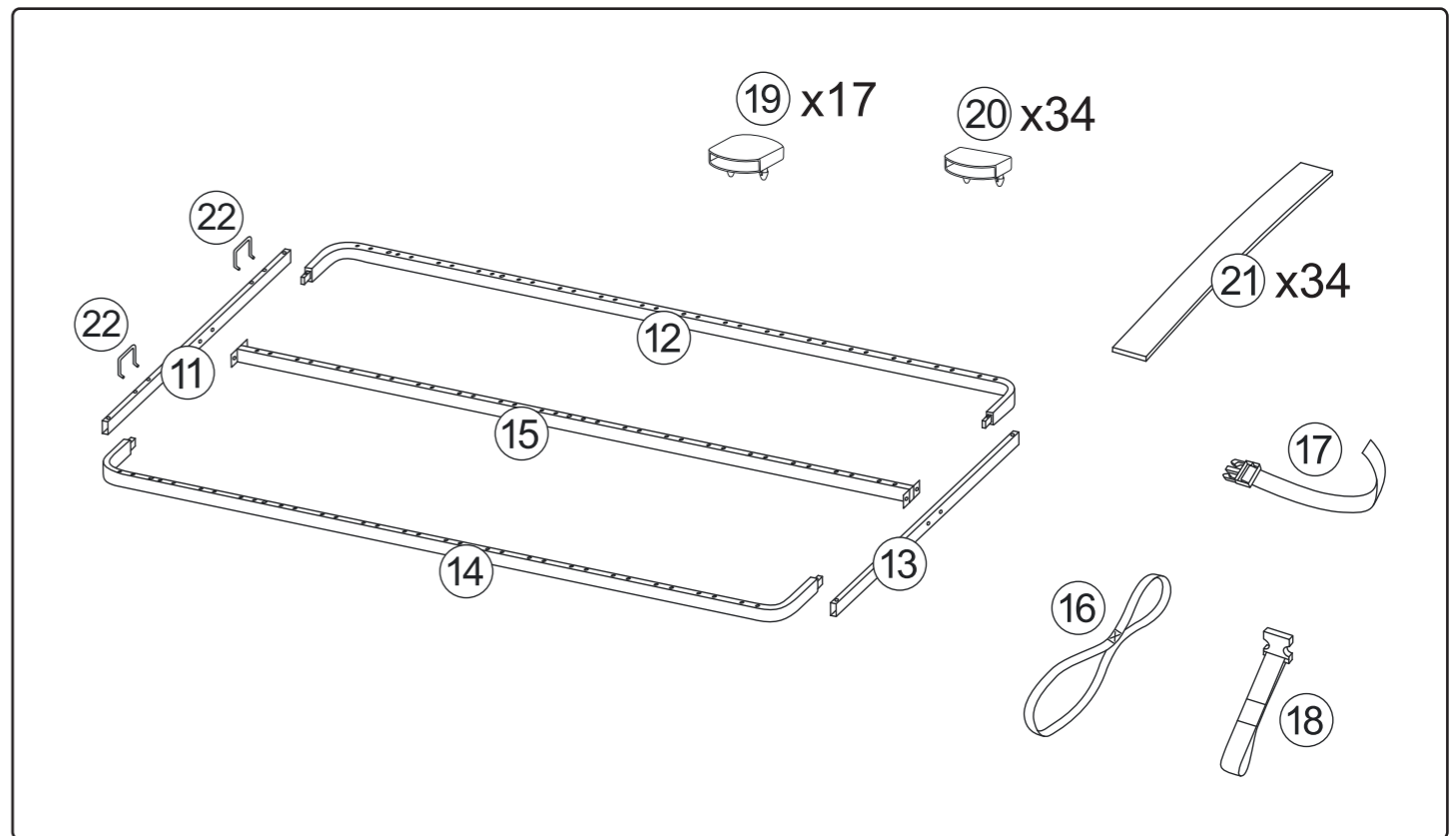

C3'

26

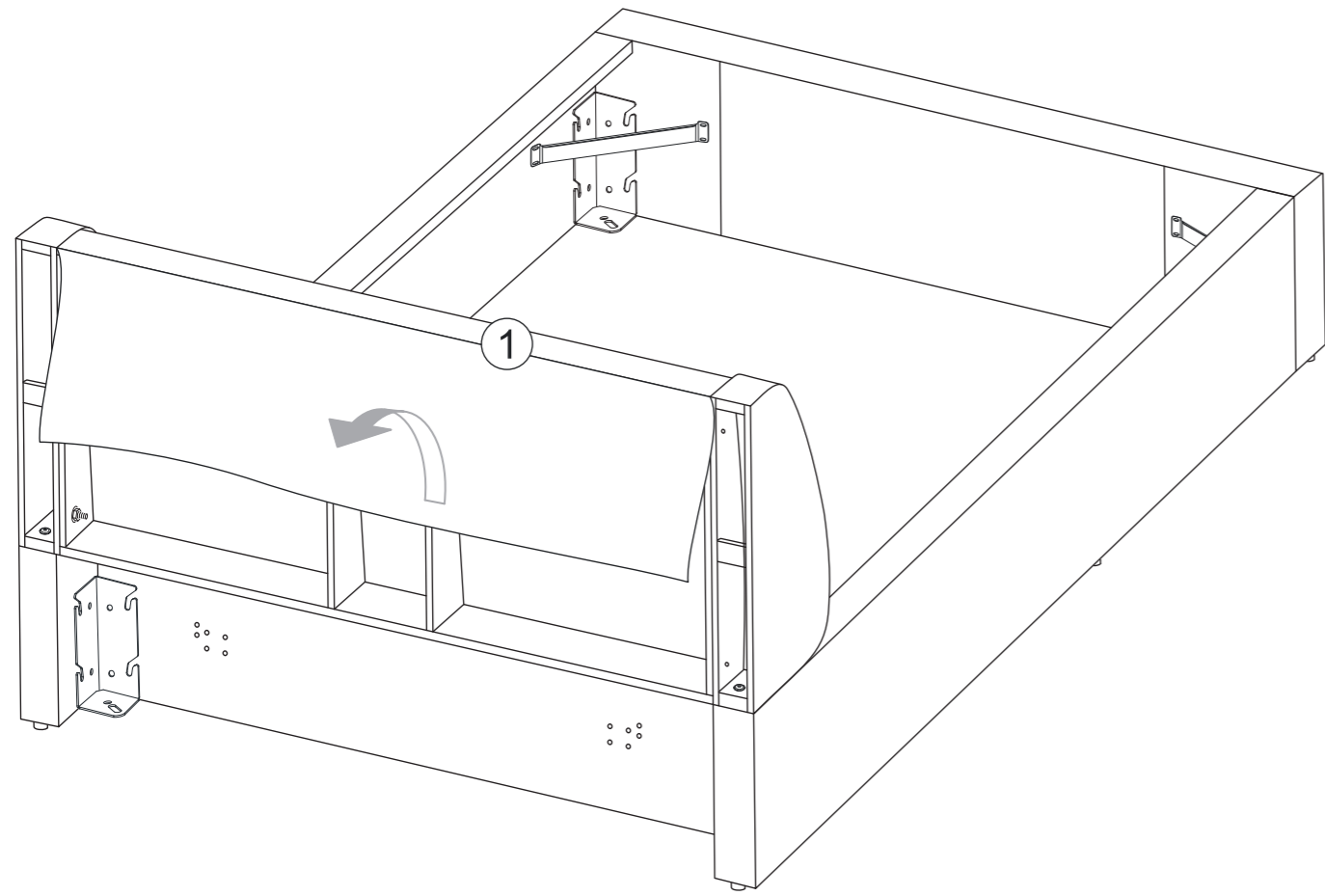



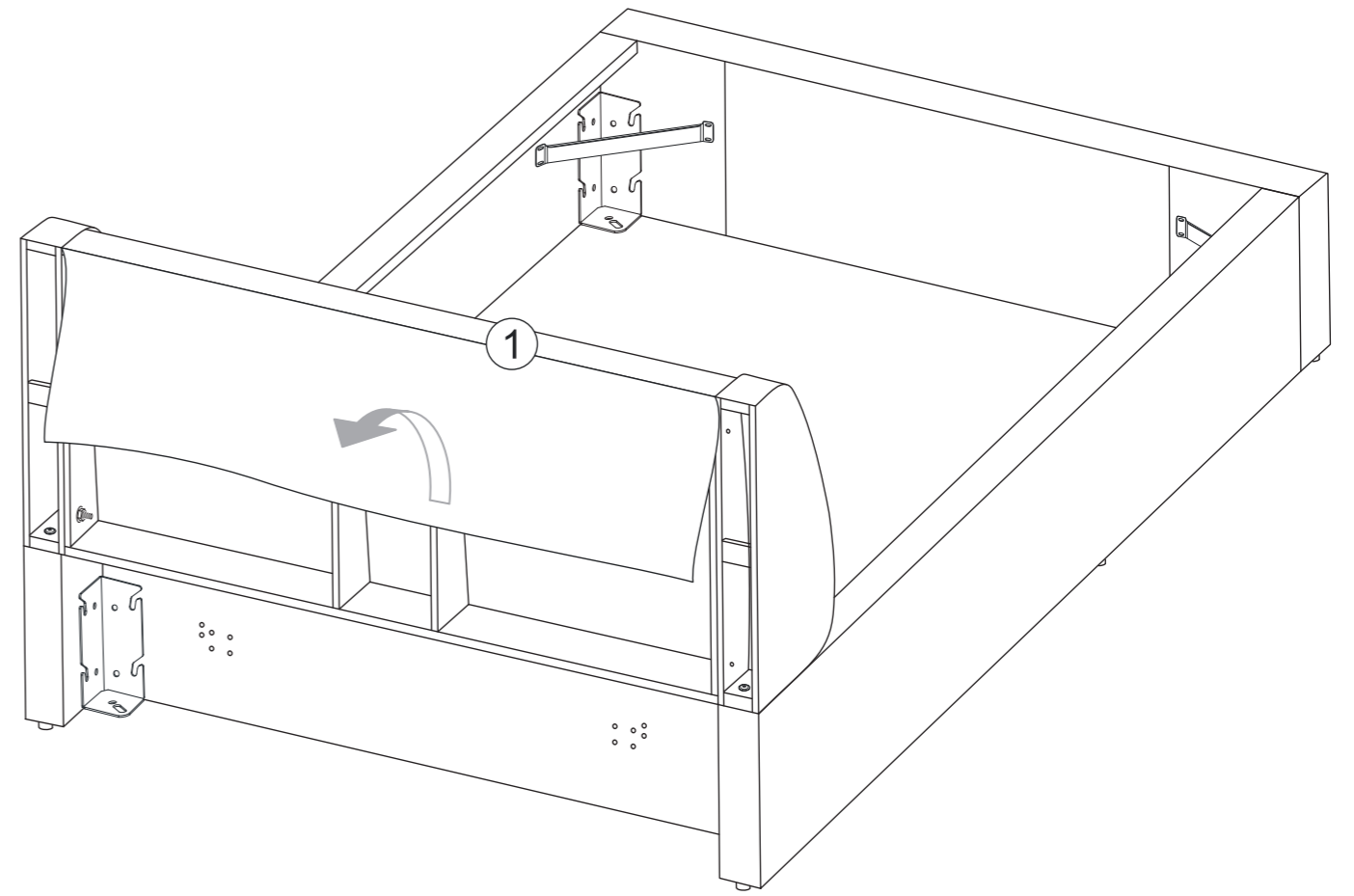

15

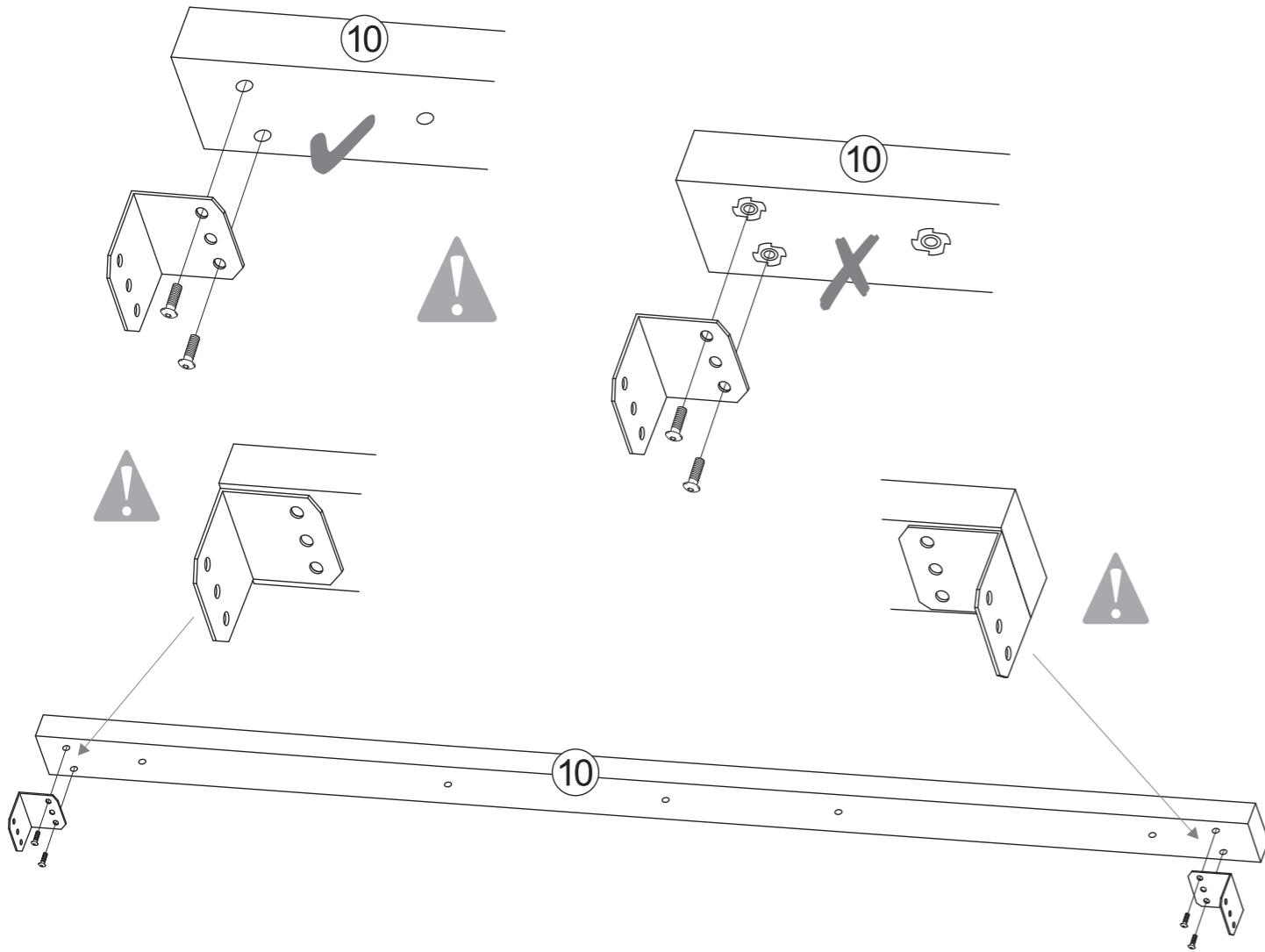

16a

⚠ Pour les dimension **B160x200** et **C180x200**

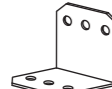

 Ax4
 Ux2
 SW5 R

16b

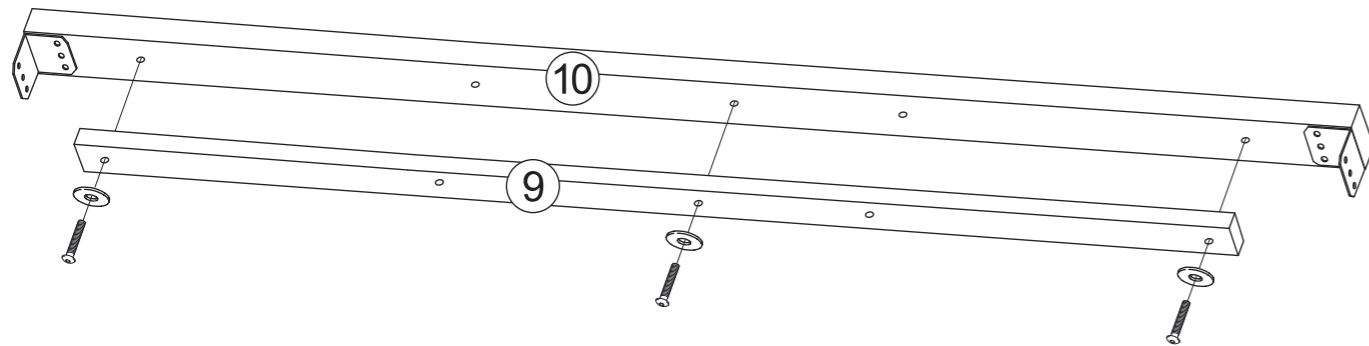

 Tx3
 lx3
 SW5 R

25

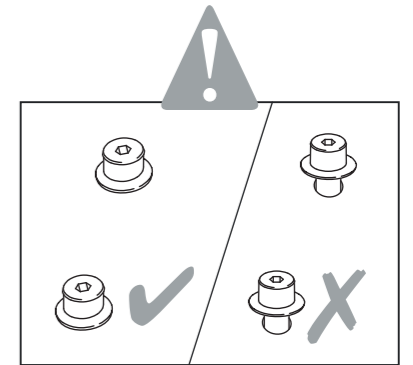
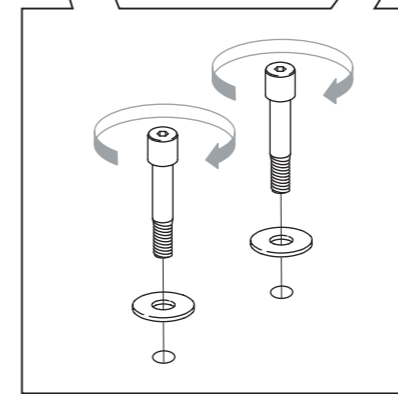
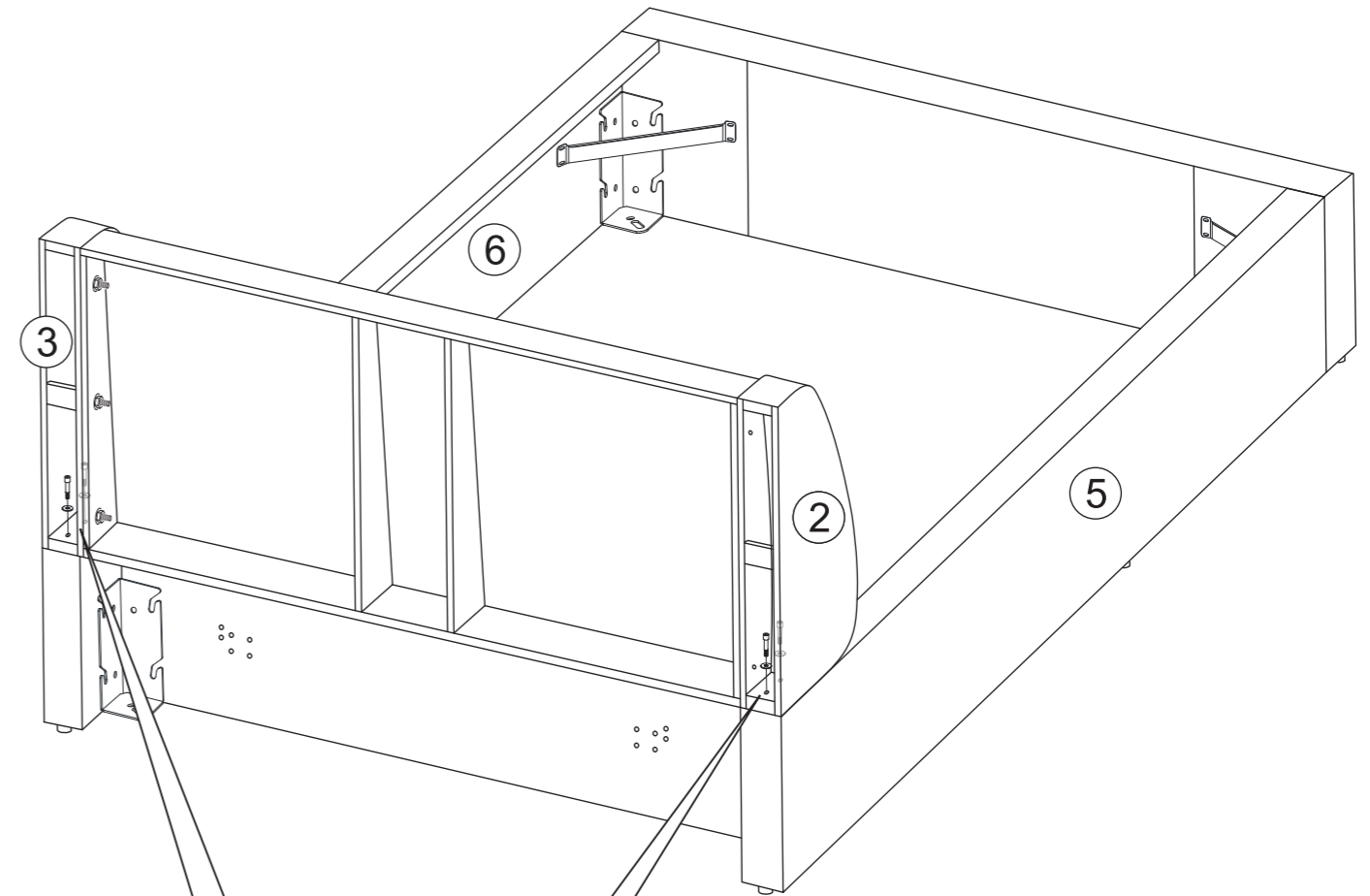

 Cx4
 Hx4
 SW5 R

23

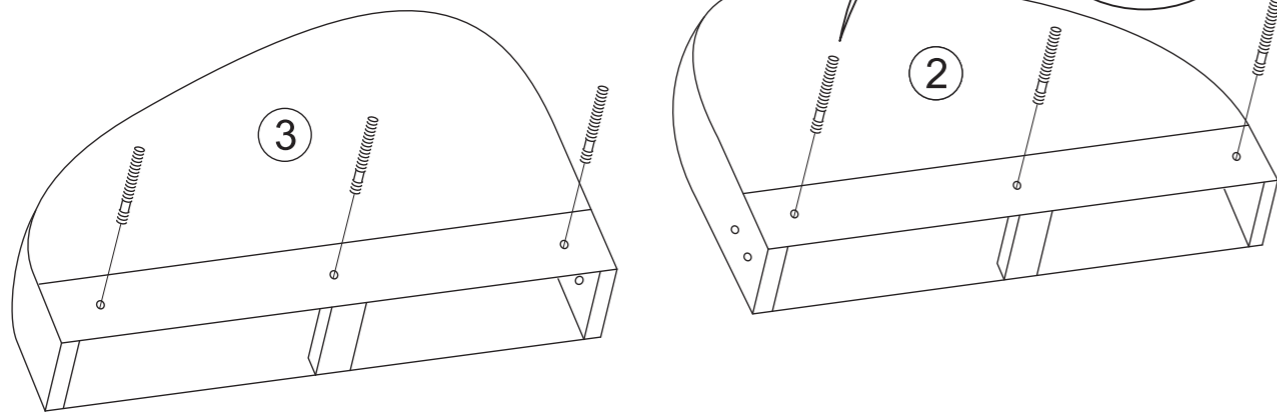
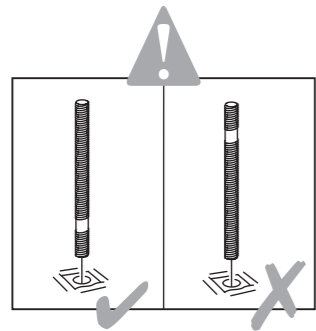

24

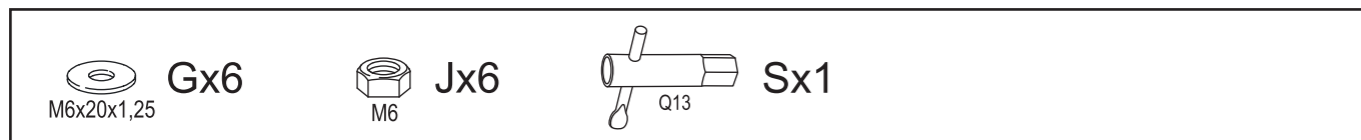
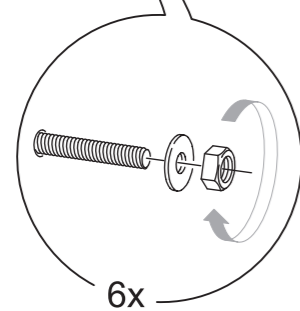
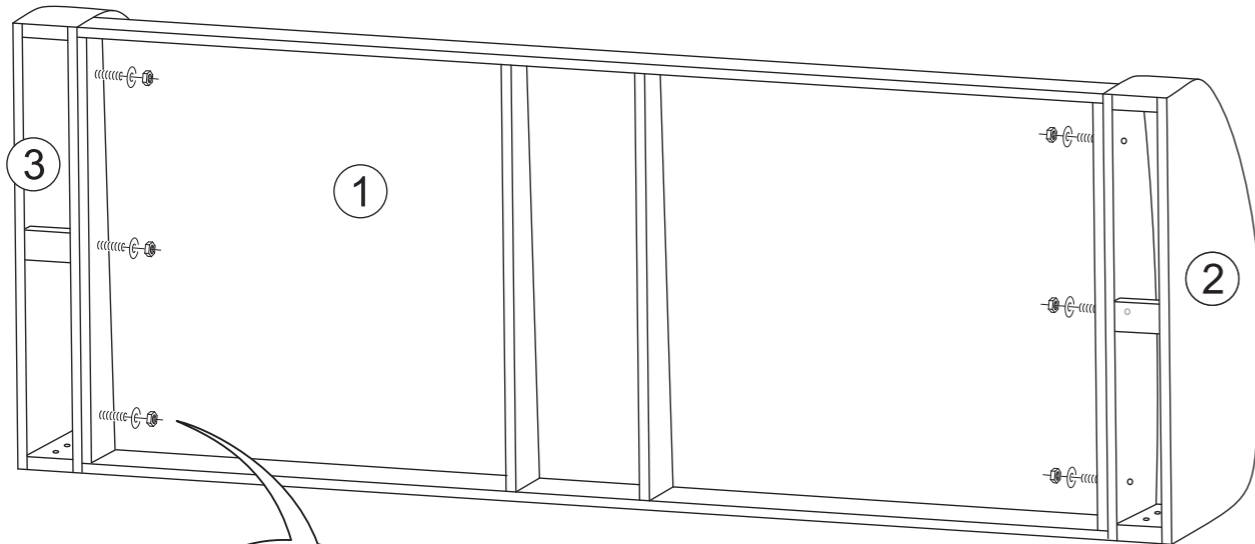

16c



B160x200
C180x200

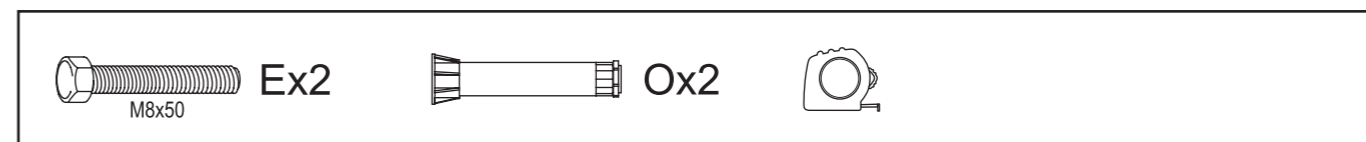
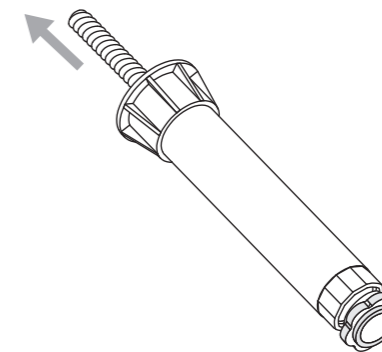
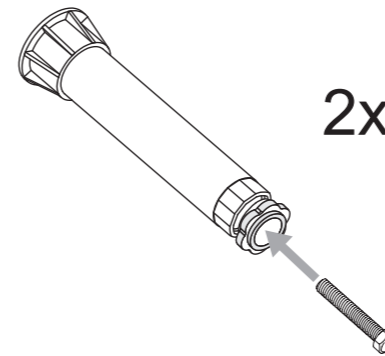
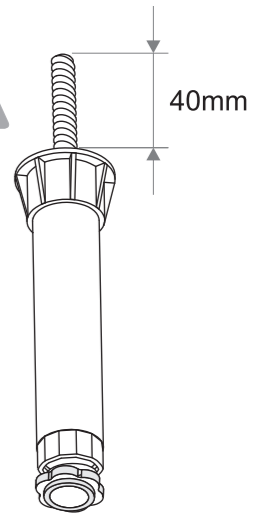

16d

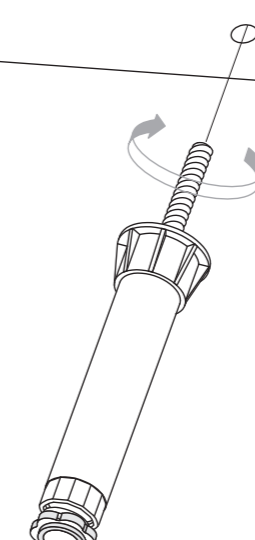
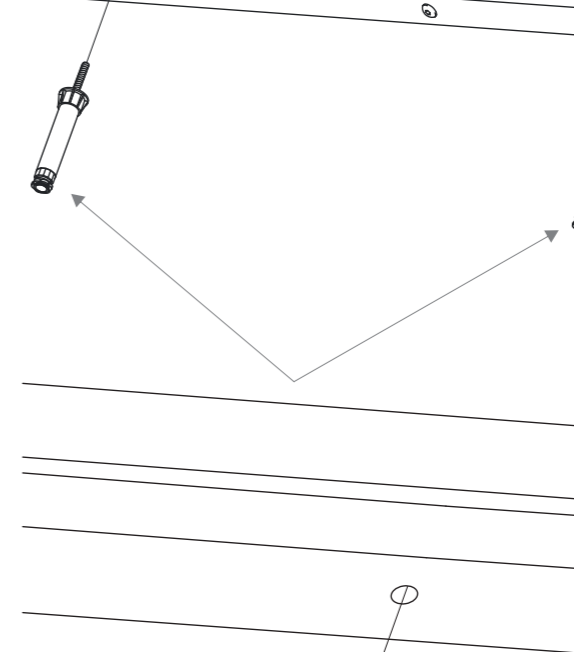
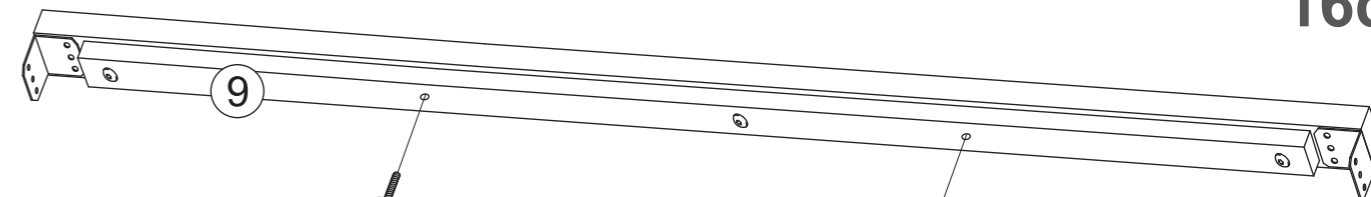

16e

 **B**160x200
C180x200

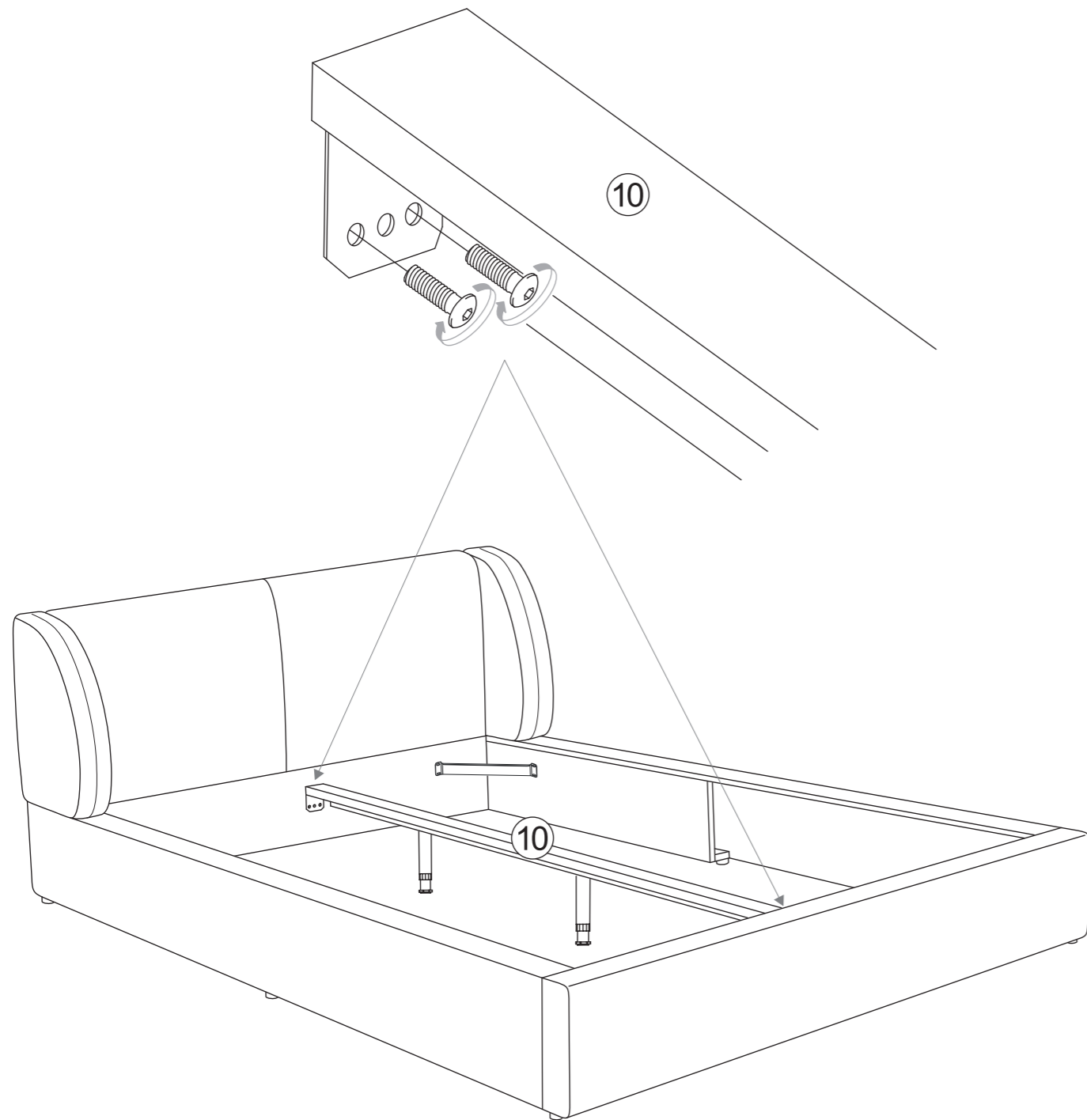

 **A**x4
M6x20

 **SW5** **R**

22

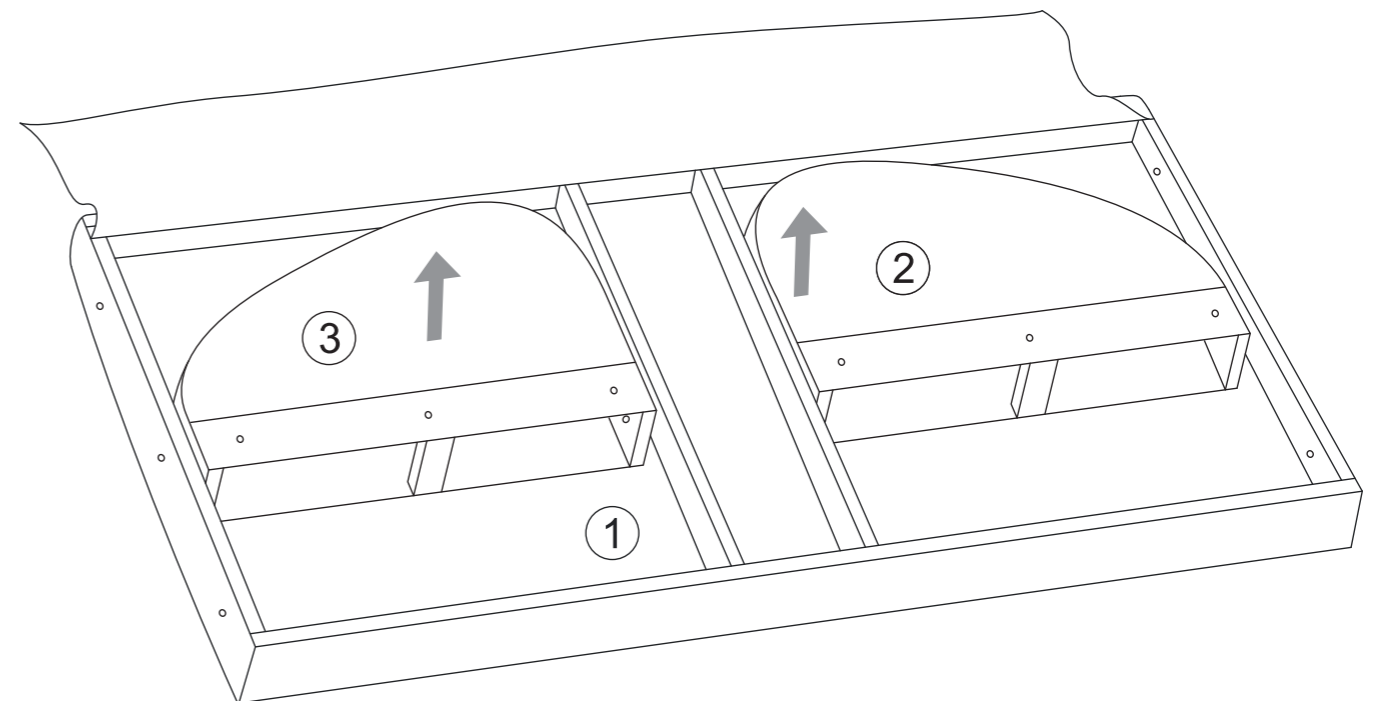
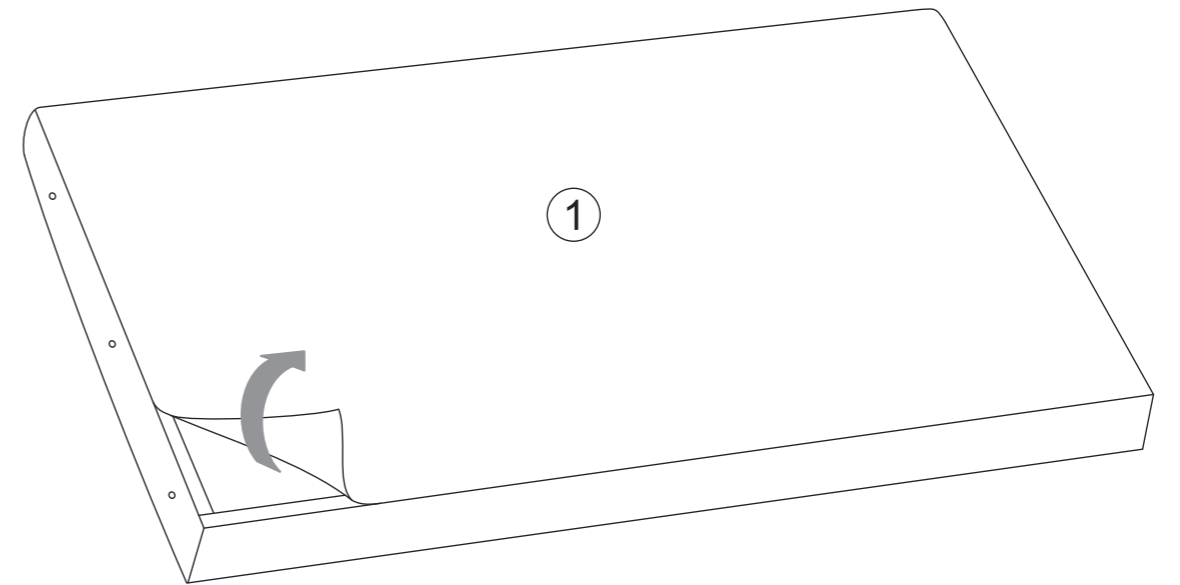

21

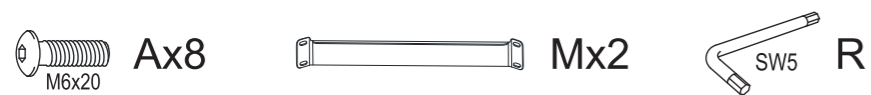
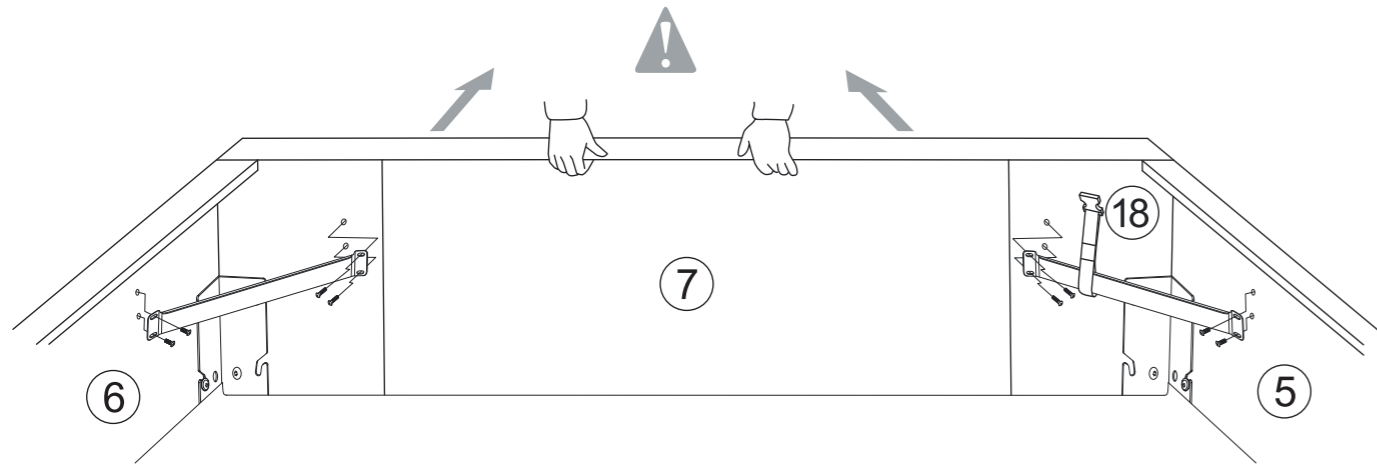
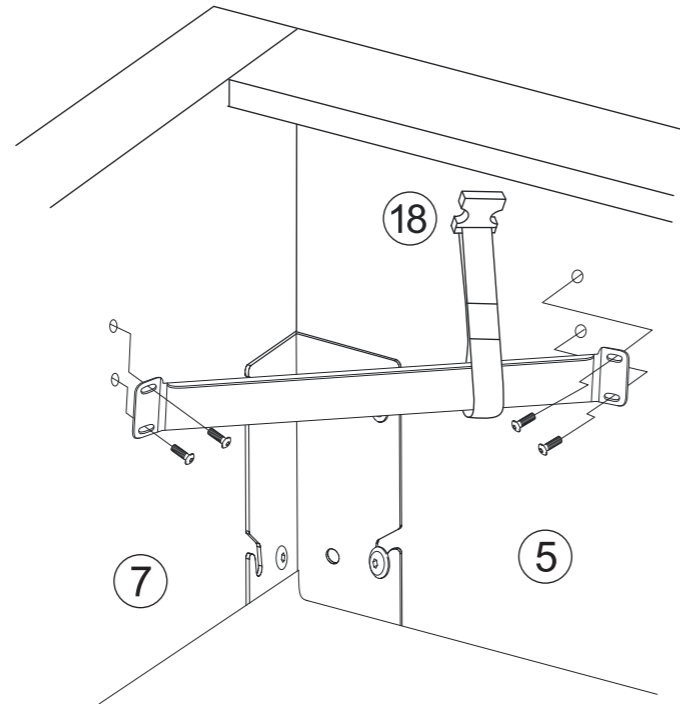
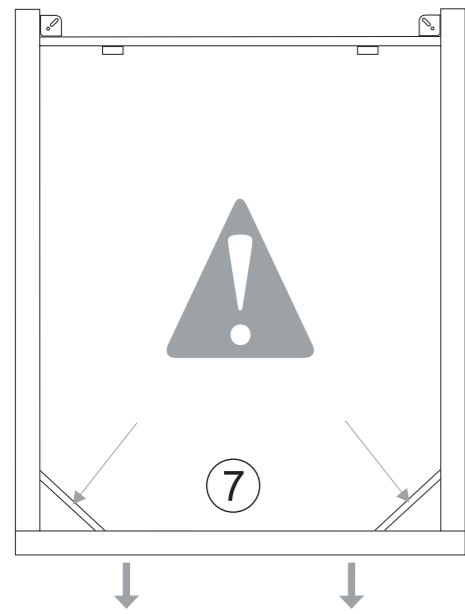
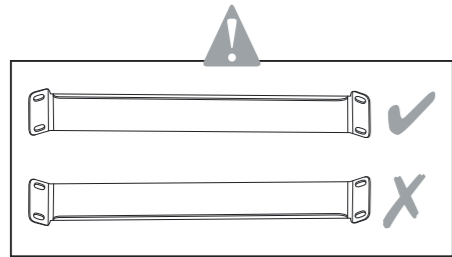
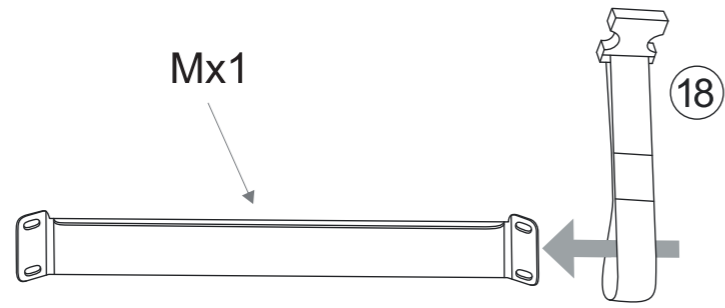

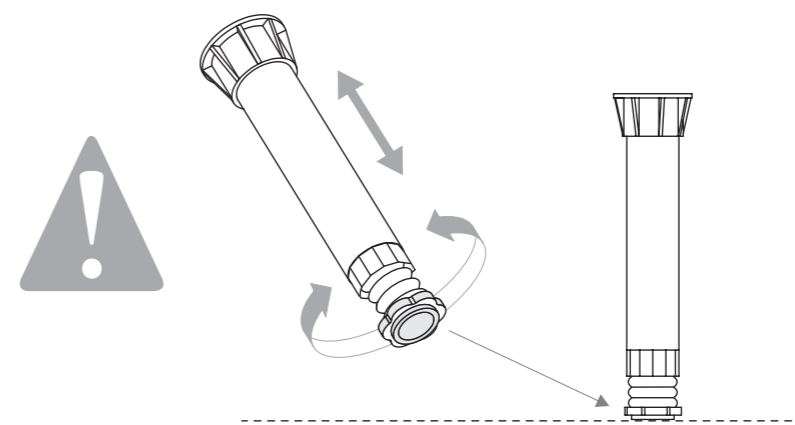
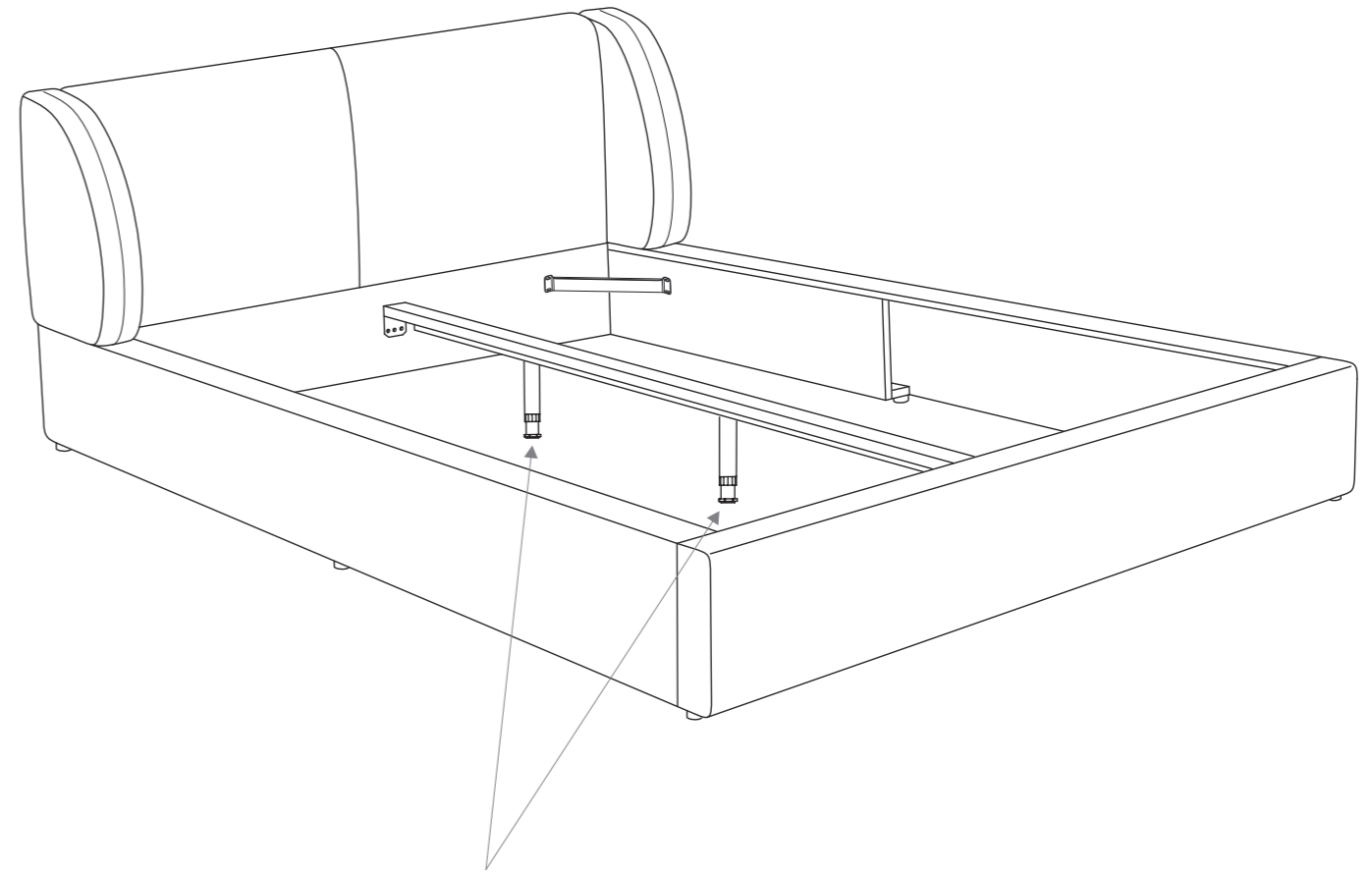

16f

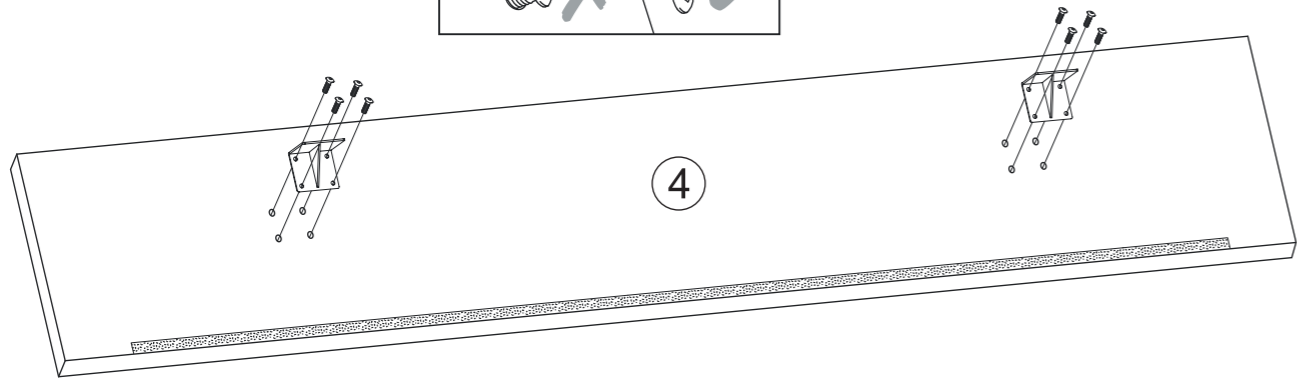
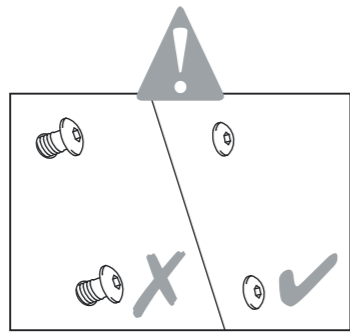

17

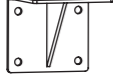

 Ax8
 Nx2
 SW5 R

18

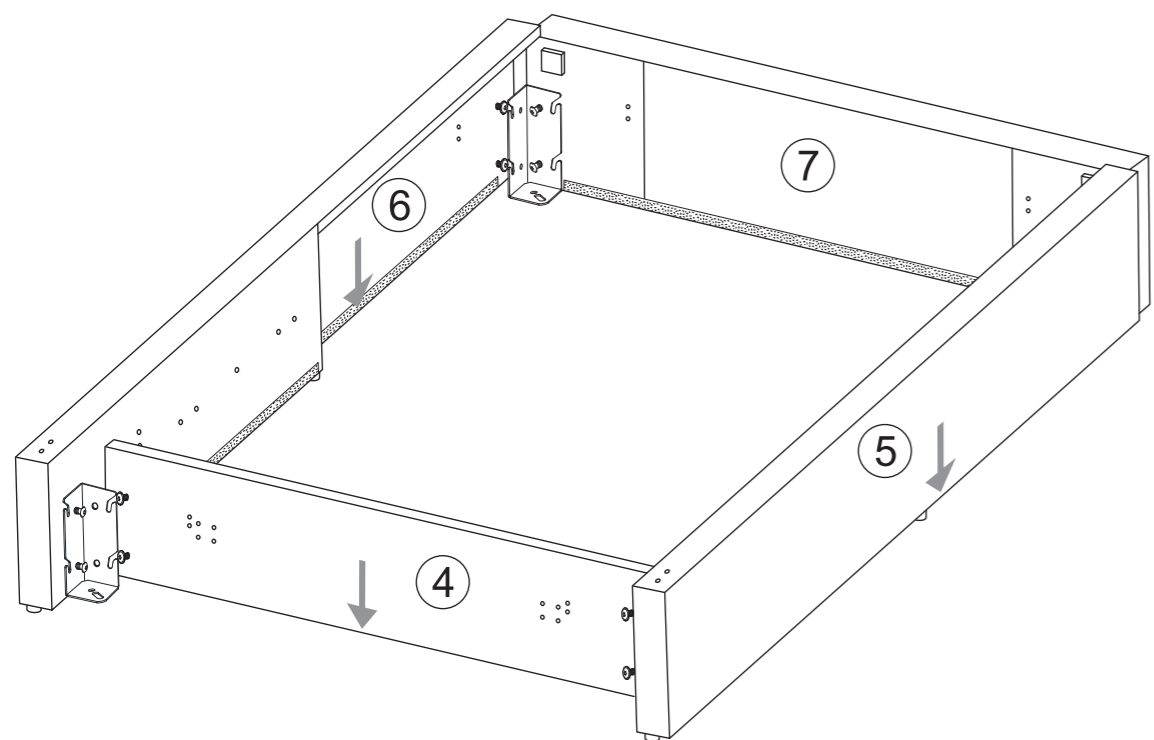
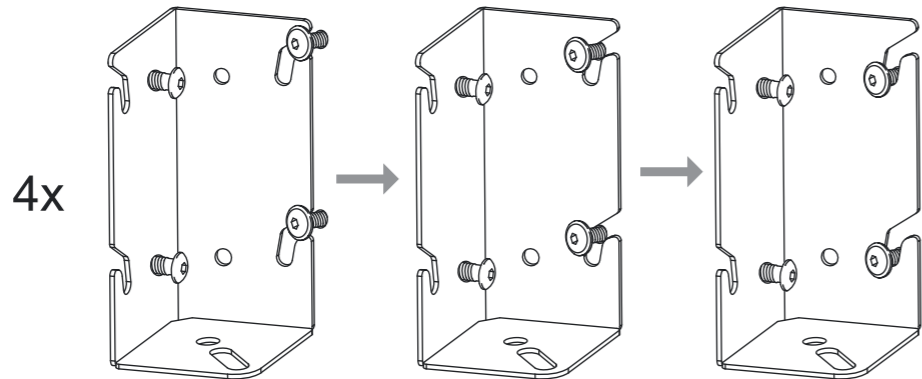

19

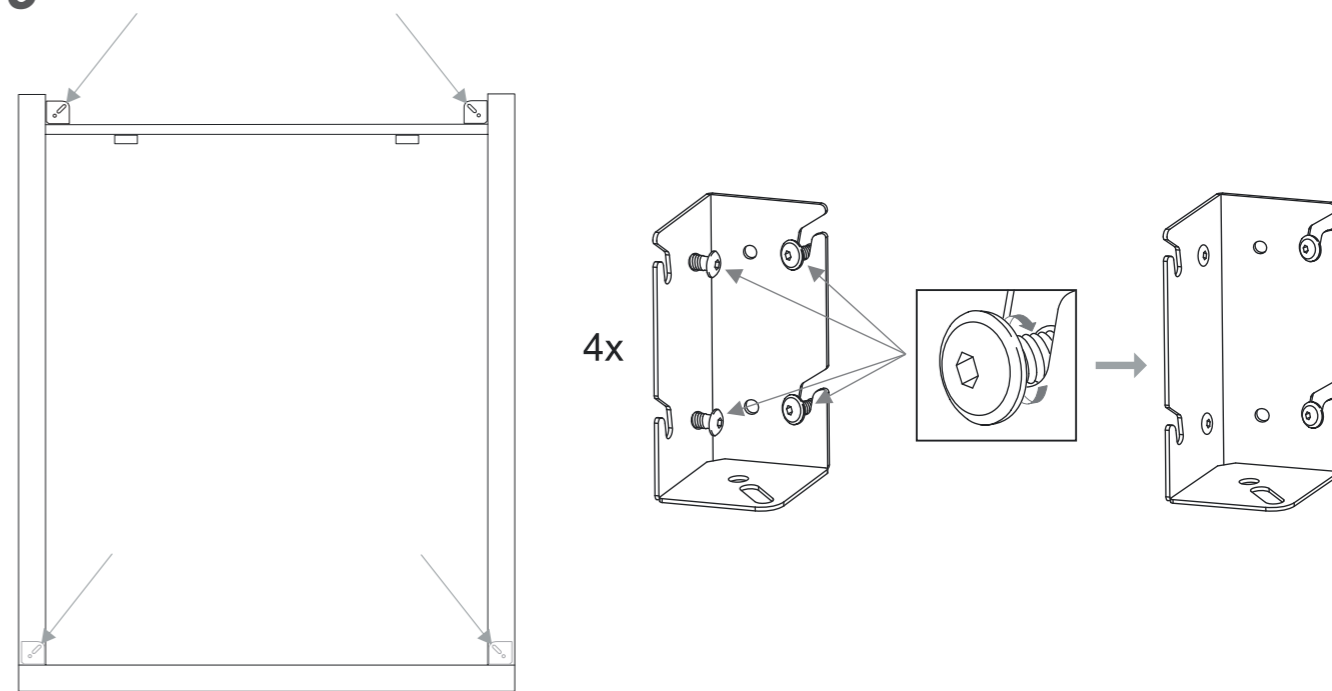

 SW5 R

20

