

# MAX

Installation



**makiba**

sav@makiba.fr - 09 72 62 17 15

Version 1 - 12/2025

# MAX

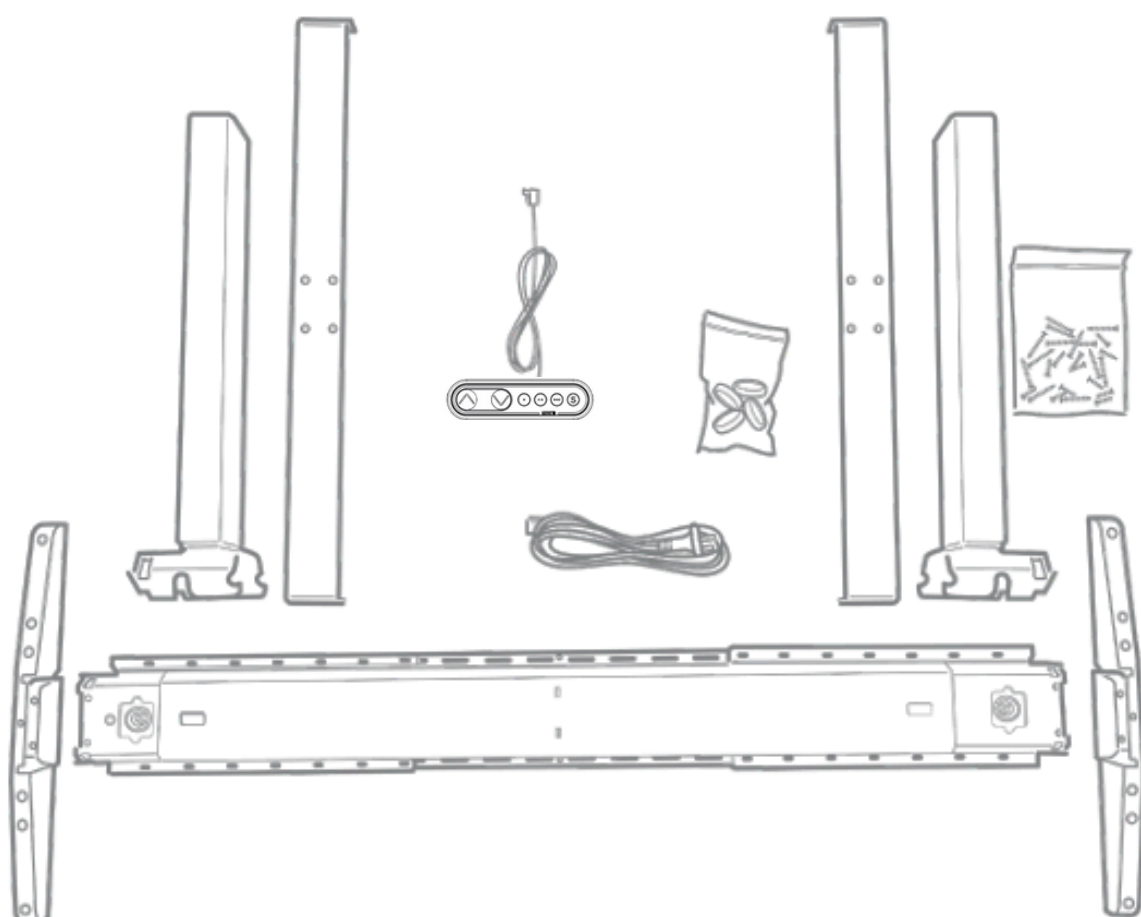

Pour plateau d'épaisseur inférieure à 25 mm, remplacer les vis 35mm par les vis 30mm fournies dans le sachet à part



OPTION :

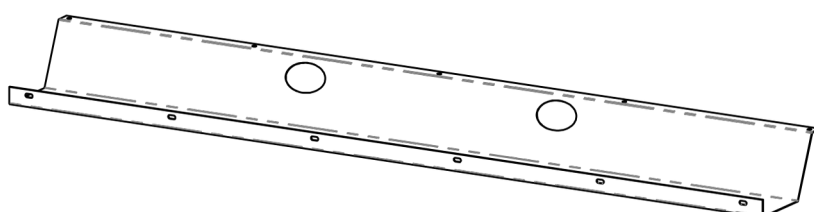

1

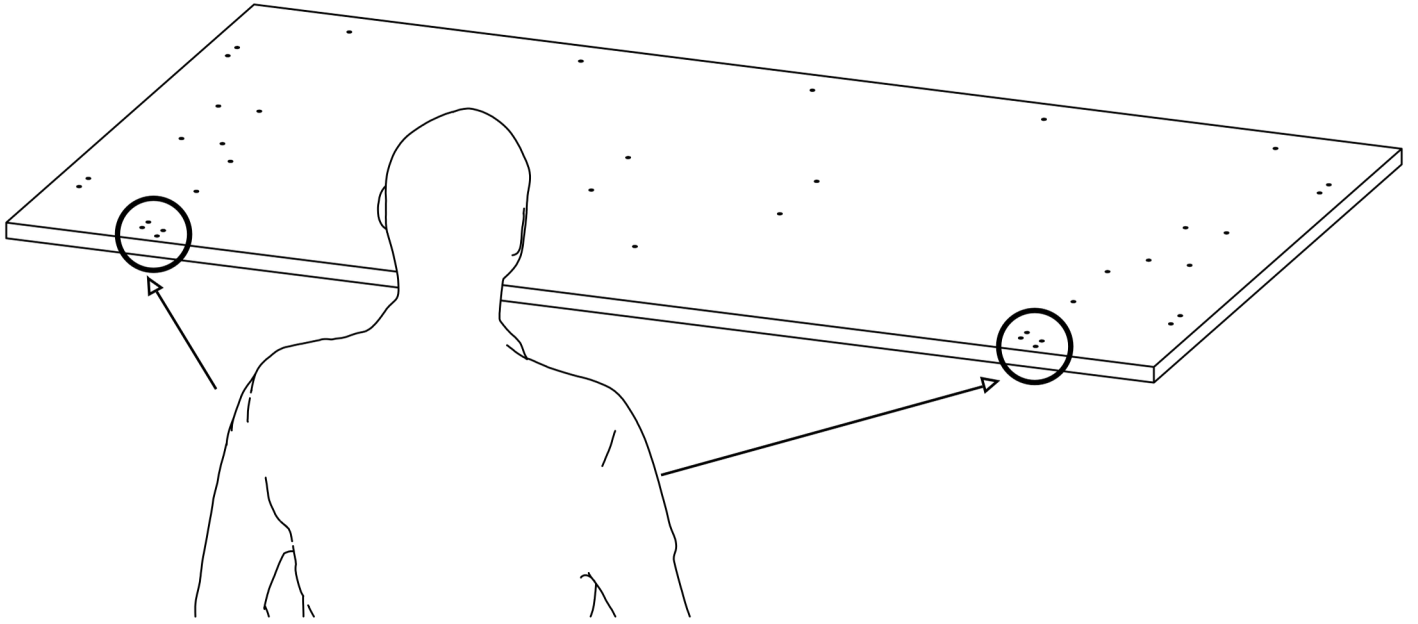

2

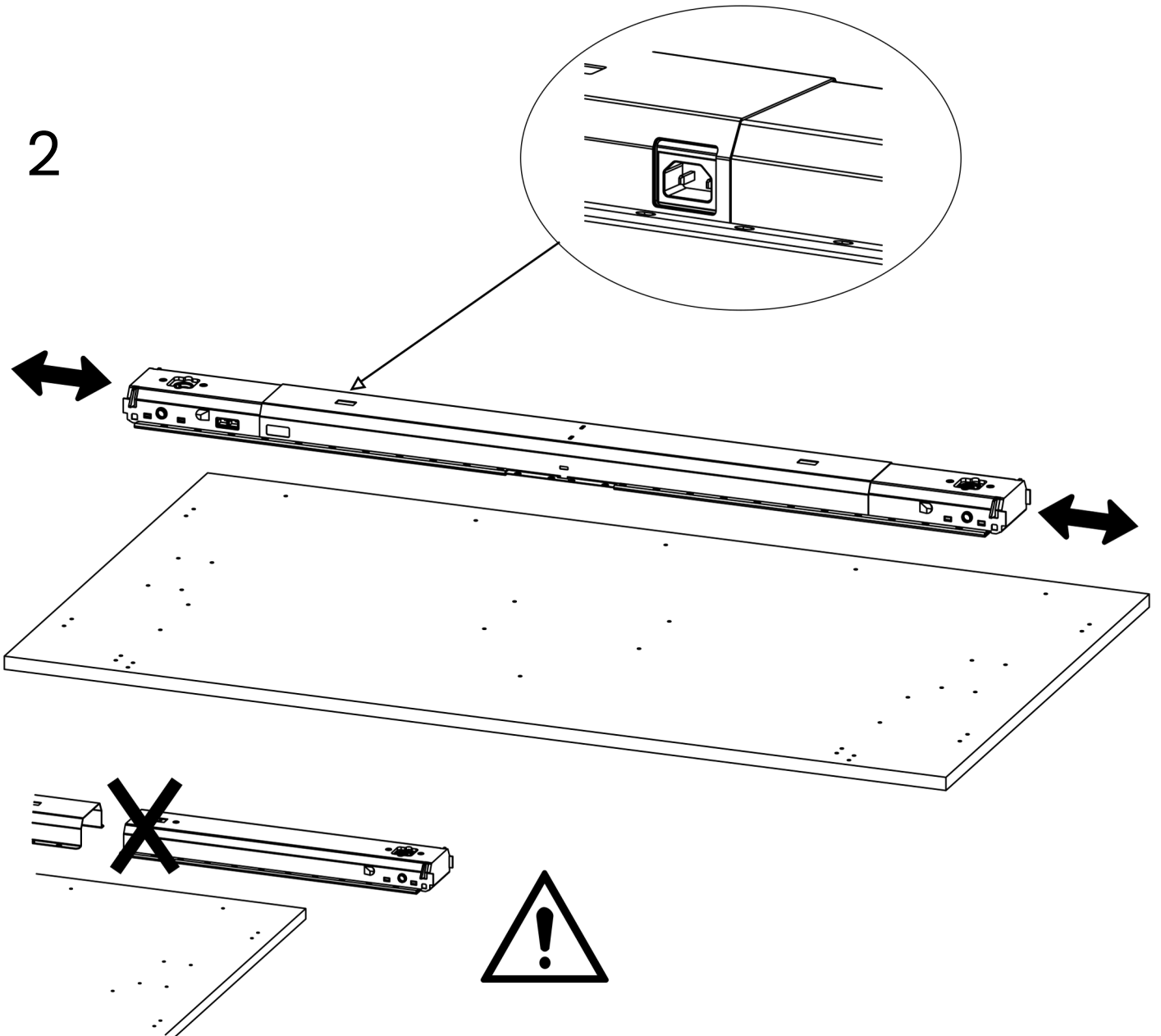

3

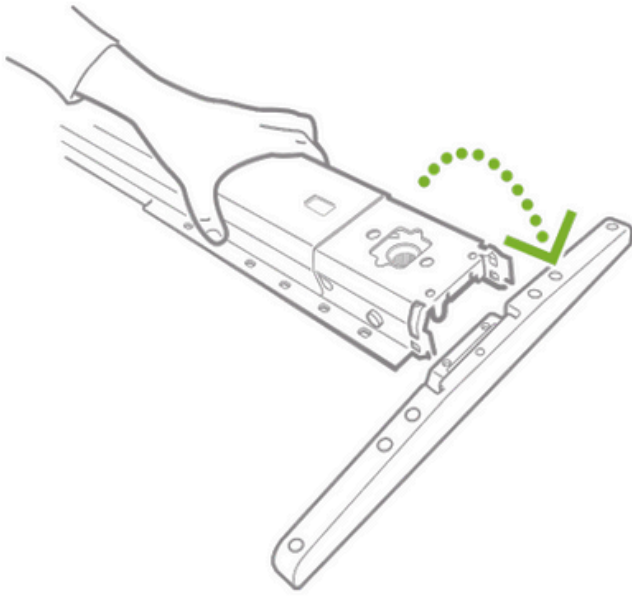

x2

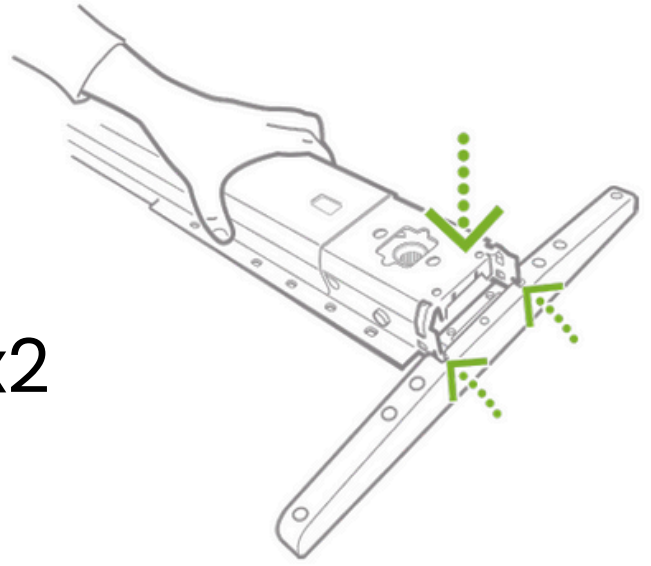

4

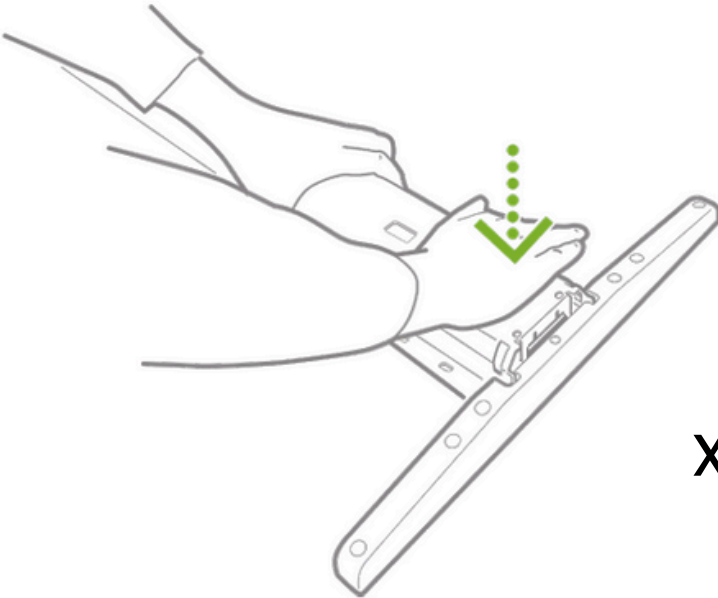

x2

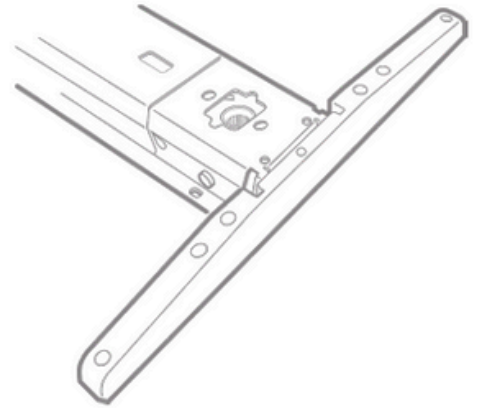

5

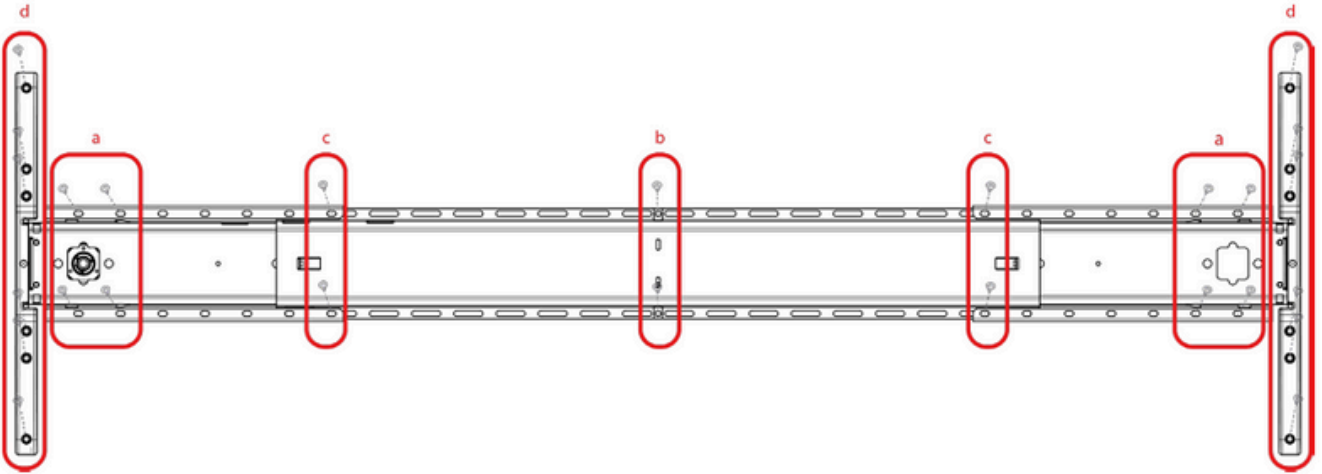

a,b,c : 4,5 x 20mm

d : 4,5x35mm si épaisseur plateau > 25 mm  
4,5x30mm si épaisseur plateau < 25 mm



6

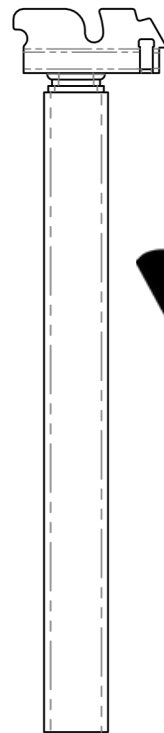
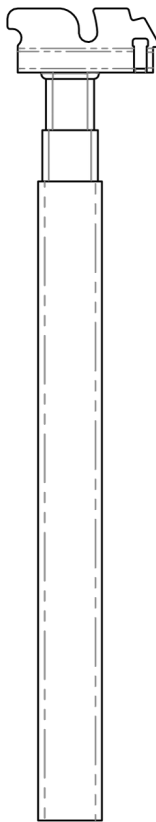
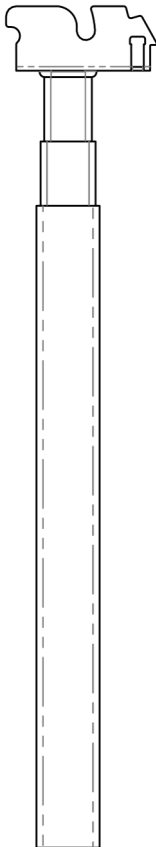

7

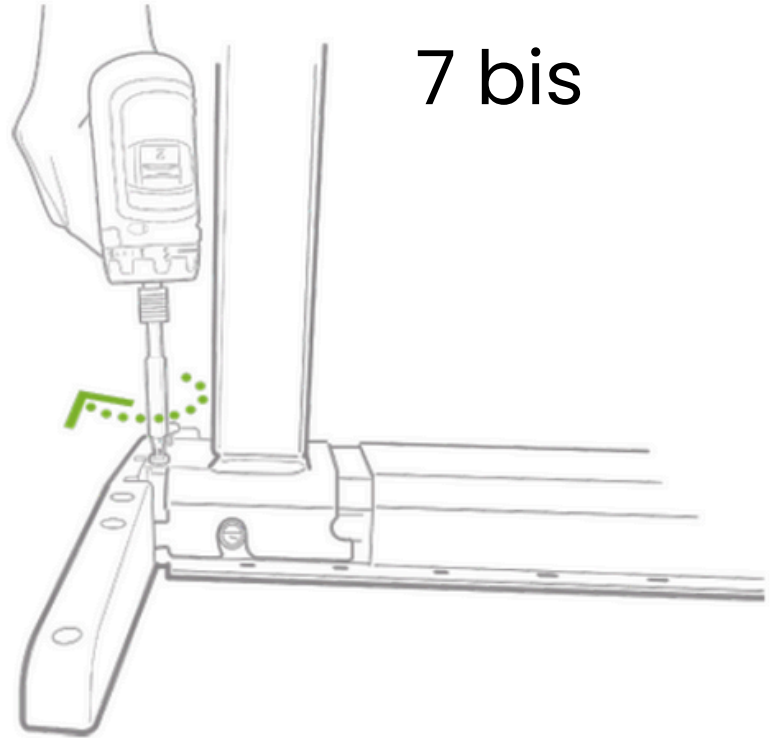

7 bis

8

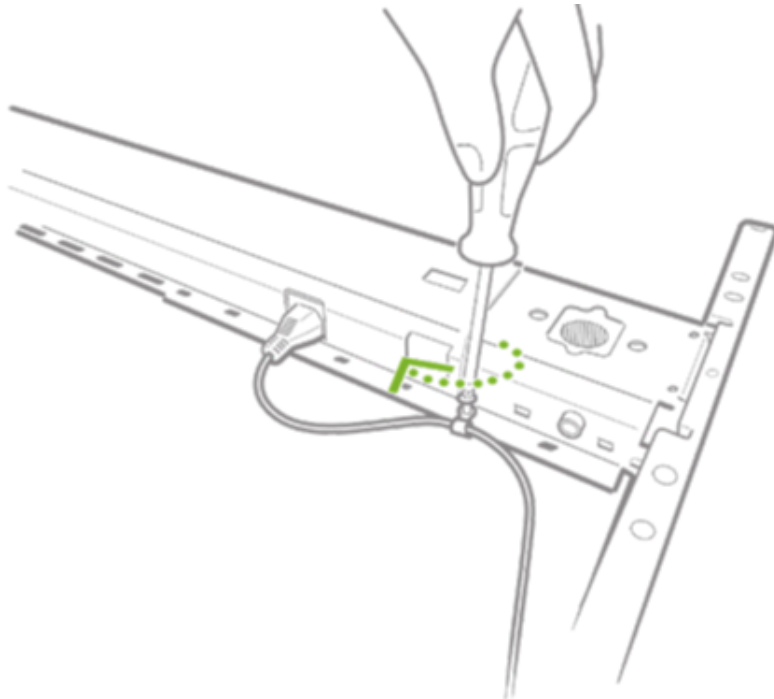

9

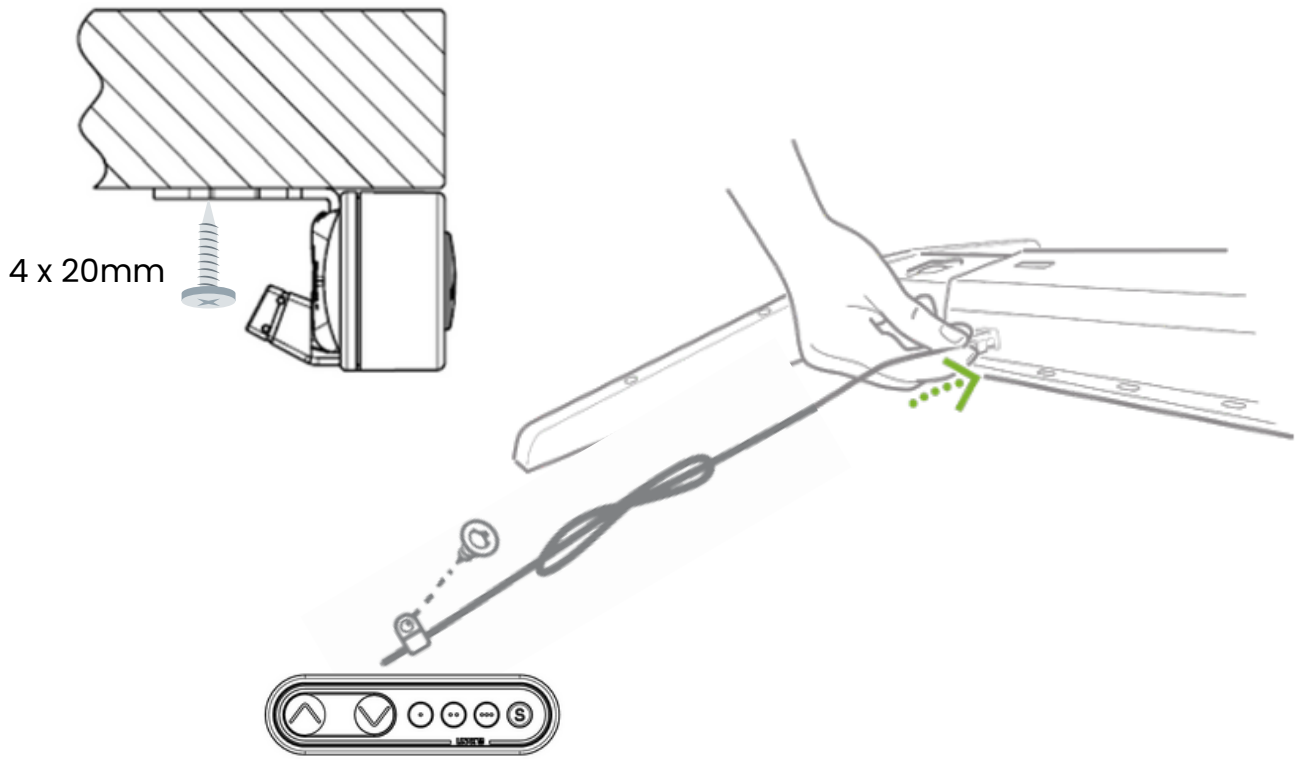

10

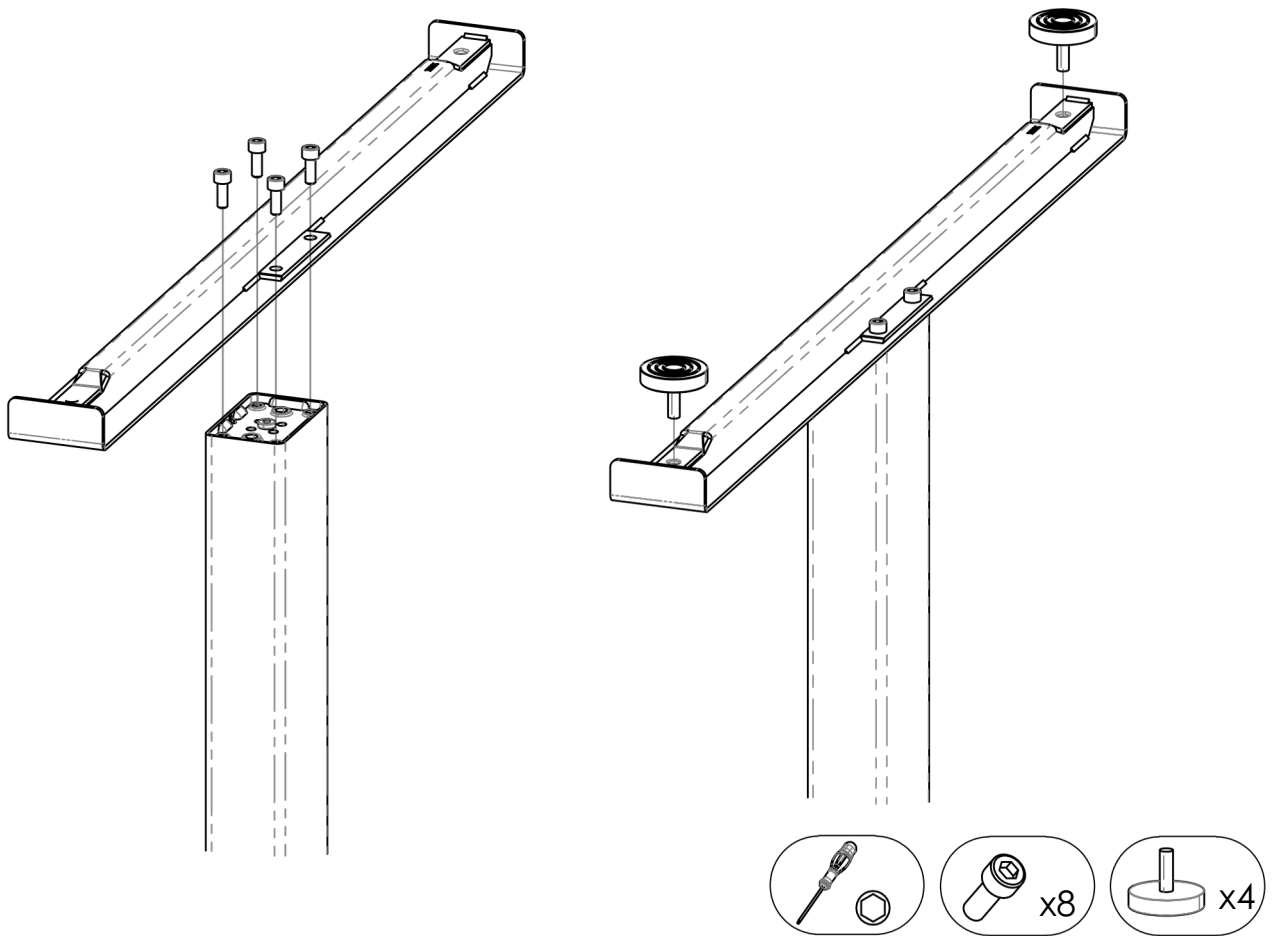

OPTION :

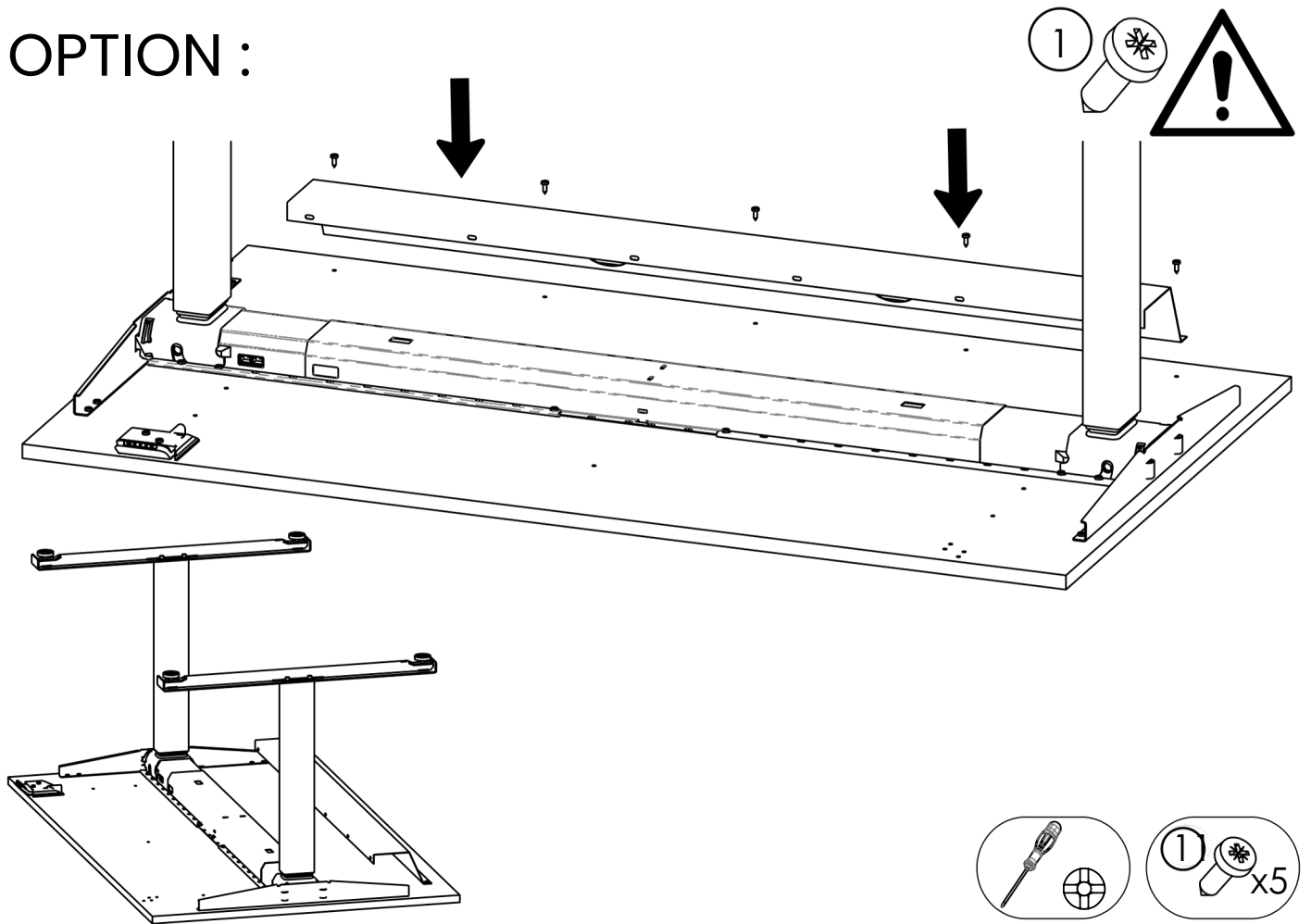

11

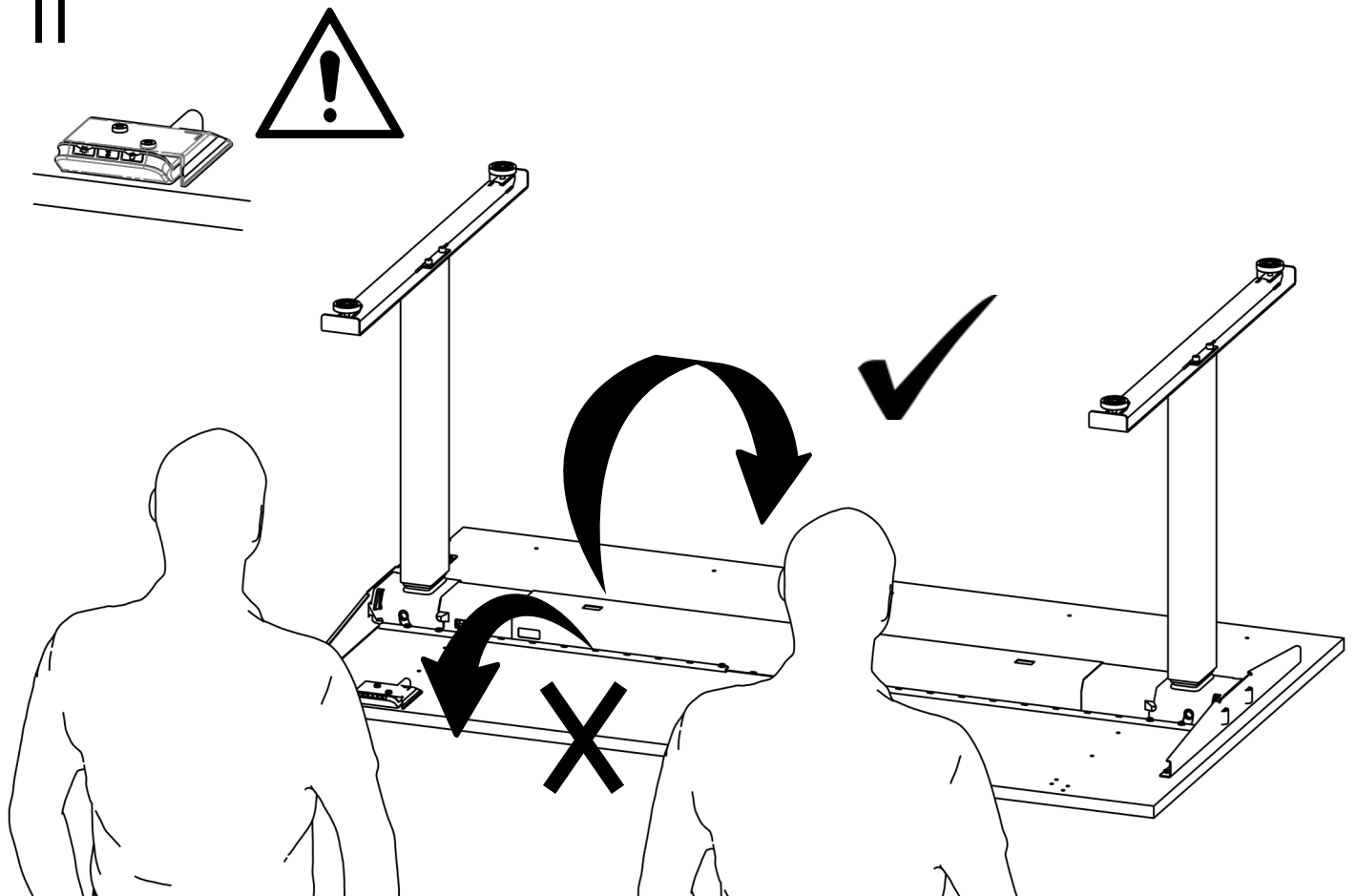

## MISE EN GARDE :

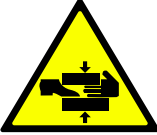

RISQUE D'ECRASEMENT - Le soulèvement ou l'abaissement du plateau, peut coincer et écraser des membres. N'UTILISEZ PAS CET EQUIPEMENT A MOINS D'AVOIR RECU UNE FORMATION ADEQUATE - Commencez par lire ce guide. CET EQUIPEMENT NE DOIT PAS ÊTRE UTILISE PAR DES ENFANTS - ni par toute autre personne incapable de comprendre les risques et d'ajuster la hauteur du bureau en toute sécurité. DEBRANCHEZ ET ATTACHEZ LE CORDON D'ALIMENTATION LORSQUE LE BUREAU N'EST PAS UTILISE AFIN D'EVITER QUE LES ENFANTS NE LE FASSENT FONCTIONNER SANS SURVEILLANCE. MAINTENEZ UN DEGAGEMENT DE 25mm AU-DESSUS DES OBJETS PLACES SUR LE BUREAU LORSQUE CELUI-CI EST A HAUTEUR MAXIMALE, AINSI QU'ENTRE LE BUREAU ET LES OBJETS ADJACENTS. - Placez le bureau, les accessoires et les objets avoisinants de façon à permettre la pleine amplitude de déplacement du plan de travail, sans risque de traction de cordes, de coincement de membres ou de collision avec d'autres objets (étagères, prises et fils électriques, poignées de portes, appuis de fenêtres, armoires, etc.). NE PLACEZ PAS LES PIEDS OU D'AUTRES PARTIES DU CORPS SUR DES ARMOIRES OU DES OBJETS SITUES SOUS LE PLAN DE TRAVAIL.

### AVERTISSEMENT :

RISQUE DE BLESSURE. Evitez de vous assoir ou de monter sur le produit. Utilisez uniquement aux fins prévues. Inspectez périodiquement. Cessez d'utiliser le produit s'il est endommagé ou si des pièces se desserrent.

## WARNING :



RISK OF CRUSHING - Lifting or lowering the tray, can jam and crush limbs. DO NOT USE THIS EQUIPMENT UNLESS YOU HAVE RECEIVED ADEQUATE TRAINING - Start by reading this guide. THIS EQUIPMENT MUST NOT BE USED BY CHILDREN - or anyone who is unable to understand the hazards and safely adjust the desk height. DEBRIEF AND ATTACH THE POWER CORD WHEN THE DESK IS NOT IN USE TO PREVENT CHILDREN FROM OPERATING IT UNATTENDED. MAINTAIN A 25mm DEGREE ABOVE THE SEAT OBJECTS ON THE DESK WHEN THE DESK IS AT MAXIMUM HEIGHT, AND BETWEEN THE DESK AND ADJACENT OBJECTS. - Position the desk, accessories and surrounding objects to allow full range of work surface motion, without risk of rope pulling, limb jamming or collision with other objects (shelves, electrical outlets and wires, door handles, window sills, cabinets, etc.). DO NOT PLACE FEET OR OTHER PARTS OF THE BODY ON CABINETS OR OBJECTS UNDER THE WORK SURFACE.

### WARNING:

RISK OF INJURY. Do not sit or climb on the product. Use only for the intended purpose. Inspect periodically. STOP using the product if it is damaged or parts become loose.

